

## C-VLU 301



### Hocheffiziente, trocken und berührungslos verdichtende Klauen-Vakuumpumpen

- Saugvermögen 265 bis 320 m<sup>3</sup>/h
- Endvakuum im Dauerbetrieb: 30 mbar (abs.)
- Flanschmotor
- Luft-Kühlung durch integrierten Lüfter
- Schallhaube, Feinsiebfilter, saugseitiges Rückschlagventil sind serienmäßig

### High efficiency, dry and contact free compression claw vacuum pumps

- Capacities ranging from 265 to 320 m<sup>3</sup>/hr
- Ultimate vacuum at continuous operation: 30 mbar (abs)
- Fitted as standard with flange motor
- Air cooling by integrated fan
- Silencing hood, fine mesh filter, vacuum non-return valve on suction side are standard

### Technische Daten • Technical data

C-VLU				301
Nennsaugvermögen <i>Nominal suction capacity</i>	m <sup>3</sup> /h	50 Hz		265
		60 Hz		320
Endvakuum im Dauerbetrieb <i>Ultimate vacuum at continuous operation</i>	mbar (abs.)	50 Hz		30
		60 Hz		30
Mittlerer Schalldruckpegel <i>Average noise level</i>	dB(A)	50 Hz		74
	ENISO3744	60 Hz		77
max. Gewicht ohne Motor <i>max. weight without motor</i>	kg			216,5
Öleinfüllmenge <i>Oil capacity</i>	l			1,5

m<sup>3</sup>/h\* bezogen auf den Zustand im Sauganschluss • *refers to suction conditions at inlet connection*

Kennlinien und Tabellenangaben (Toleranz ±10%) sind ermittelt nach PNEUROP und beziehen sich auf betriebswarme Vakuumpumpen (1bar (abs.) und 20°C).  
*Curves and tables content (tolerance ±10%) according to PNEUROP standards and refer to vacuum pump at normal operating temperature (1bar (abs.) and 20°C).*

Messflächenschalldruckpegel nach EN ISO 3744, gemessen an einem gleichwertigen Aggregat in 1 m Abstand bei 400 mbar (a), saugseitig angeschlossene Leitung, mit Vakuumbegrenzungsventil, Toleranz ± 3 dB (A). • *Measuring surface sound pressure level acc. to EN ISO 3744, measured with an equivalent unit at a distance of 1 m. The pump is throttled to 400 mbar (a) suction pressure, with suction side piping connected and vacuum relief valves fitted, tolerance ± 3 dB (A).*

Abbildung zeigt ggf. optionales Zubehör. • *The picture shows possibly optional accessories.*

### Motoren • Motors

3~ Motoren • 3~ motors														
Variante <i>Version</i>	50 Hz						60 Hz				Bemerkung <i>Note</i>	Gewicht <i>Weight</i>	a*	ow*
	kW	V ± 10%	min <sup>-1</sup>	A	kW	V ± 10%	min <sup>-1</sup>	A						
301	HI	IE3	5,5	400/690	2930	10,1/5,86	-	-	-	-	UL (US), CSA, CC-Nr., EAC	60	1076	260
	HL	IE4	7,5	400/690	2935	14,0/8,10	9,0	-/460	3520	-/14,4	UL (US), CSA, CC-Nr., EAC	69	1076	260
	NI	IE4	5,5	400/690	2935	10,2/5,89	-	-	-	-	UL (US), CSA, CC-Nr., EAC	69	1074	260

Die Motoren sind nach EN 60034-1 / -2 / -30 (IEC 60034) und Wärmeklasse F ausgeführt. • *The motors comply with EN 60034-1 / -2 / -30 (IEC 60034) and thermal class F.*

a\* Gesamtlänge (siehe Abmessungen) • *Total length (see dimensions)*

ow\* Motordurchmesser (siehe Abmessungen) • *Motor diameter (see dimensions)*

# auf Anfrage • *on request*

Technische Änderungen vorbehalten! • *We reserve the right to alter technical information!*

C-VLU 301

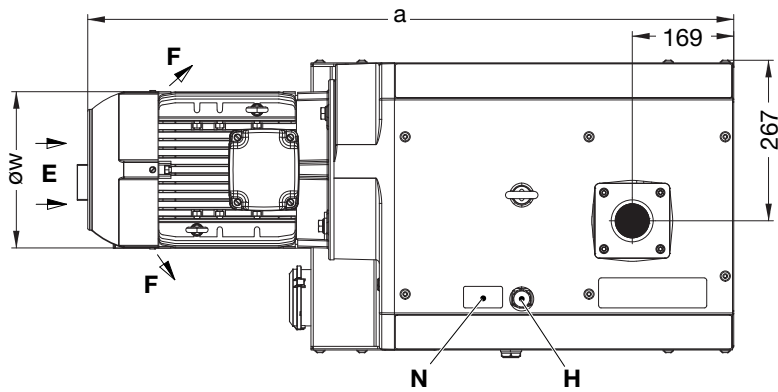
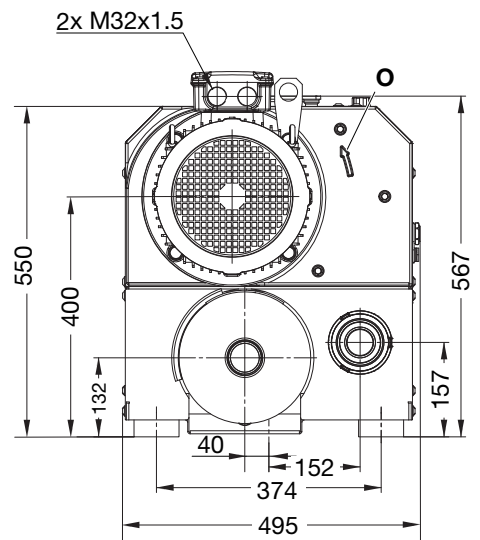
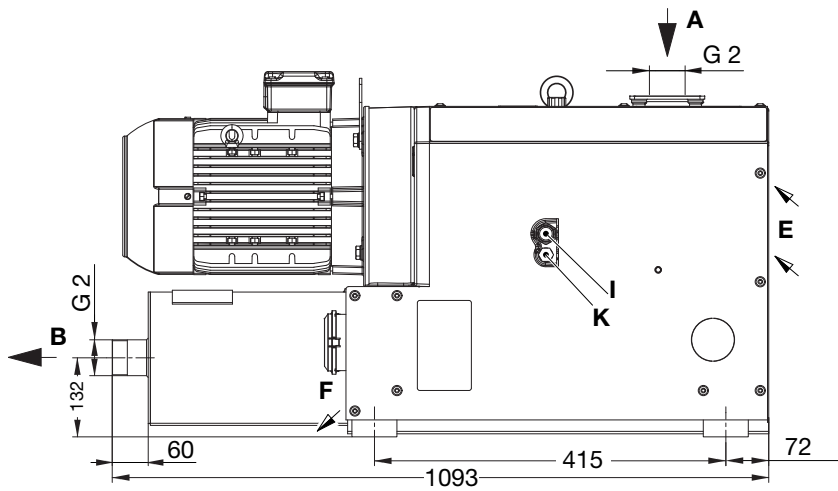

<b>A</b>	Vakuum-Anschluss • Vacuum connection
<b>B</b>	Abluft-Austritt • Exhaust
<b>E</b>	Kühlluft-Eintritt • Cooling air inlet
<b>F</b>	Kühlluft-Austritt • Cooling air outlet
<b>H</b>	Öleinfüllstelle • Oil filling point

<b>I</b>	Ölschauglas • Oil sight glass
<b>K</b>	Ölablassstelle • Oil drain point
<b>N</b>	Datenschild • Data plate
<b>O</b>	Drehrichtungsschild • Direction of rotation

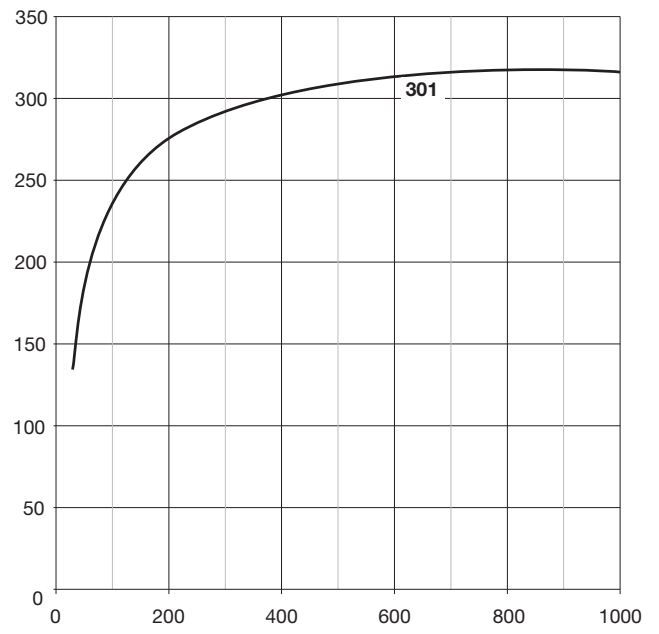
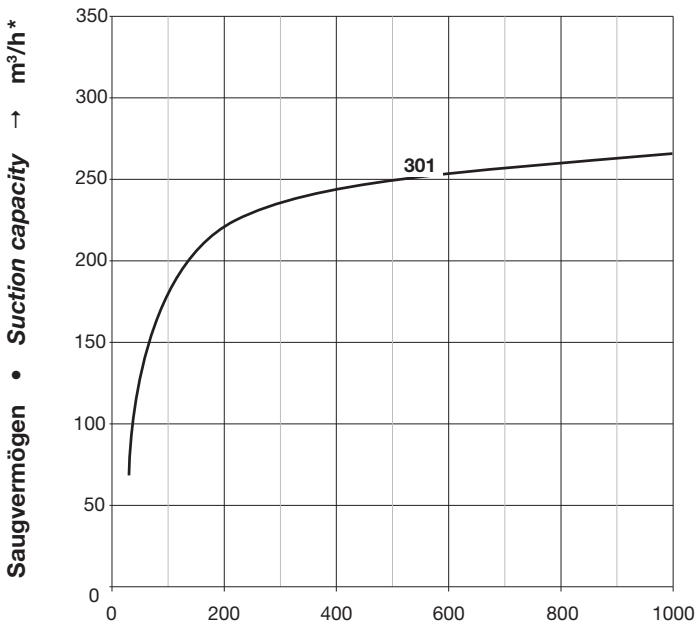

Ansaugdruck • Suction pressure → mbar (abs.)

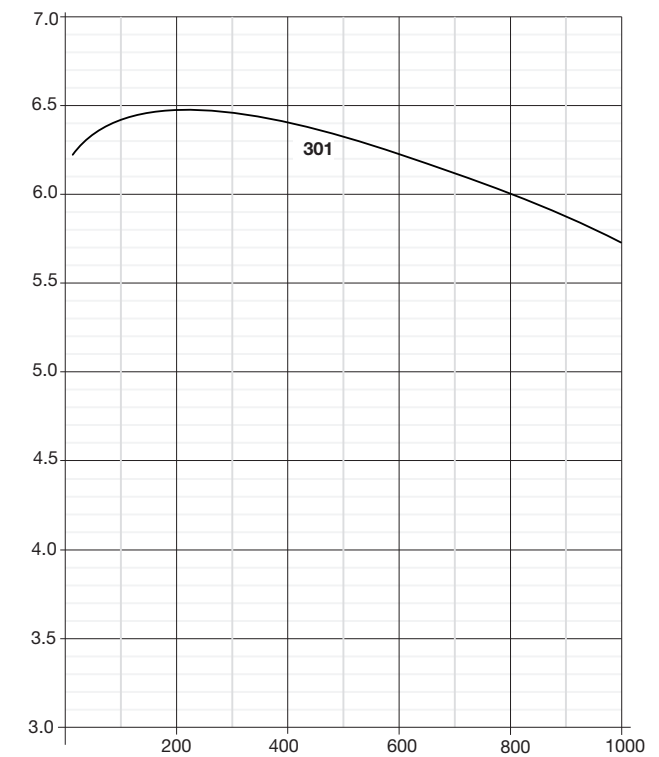
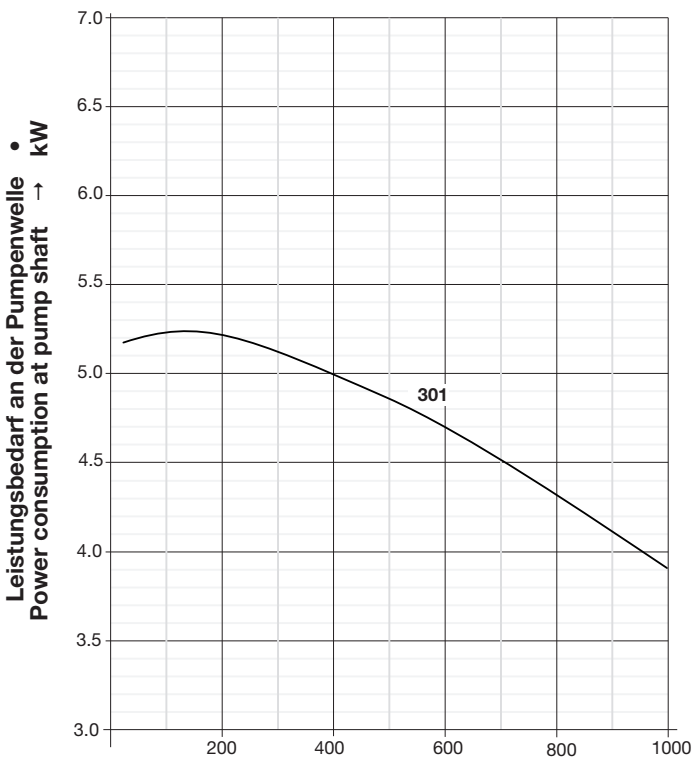

Ansaugdruck • Suction pressure → mbar (abs.)