

VWP 500

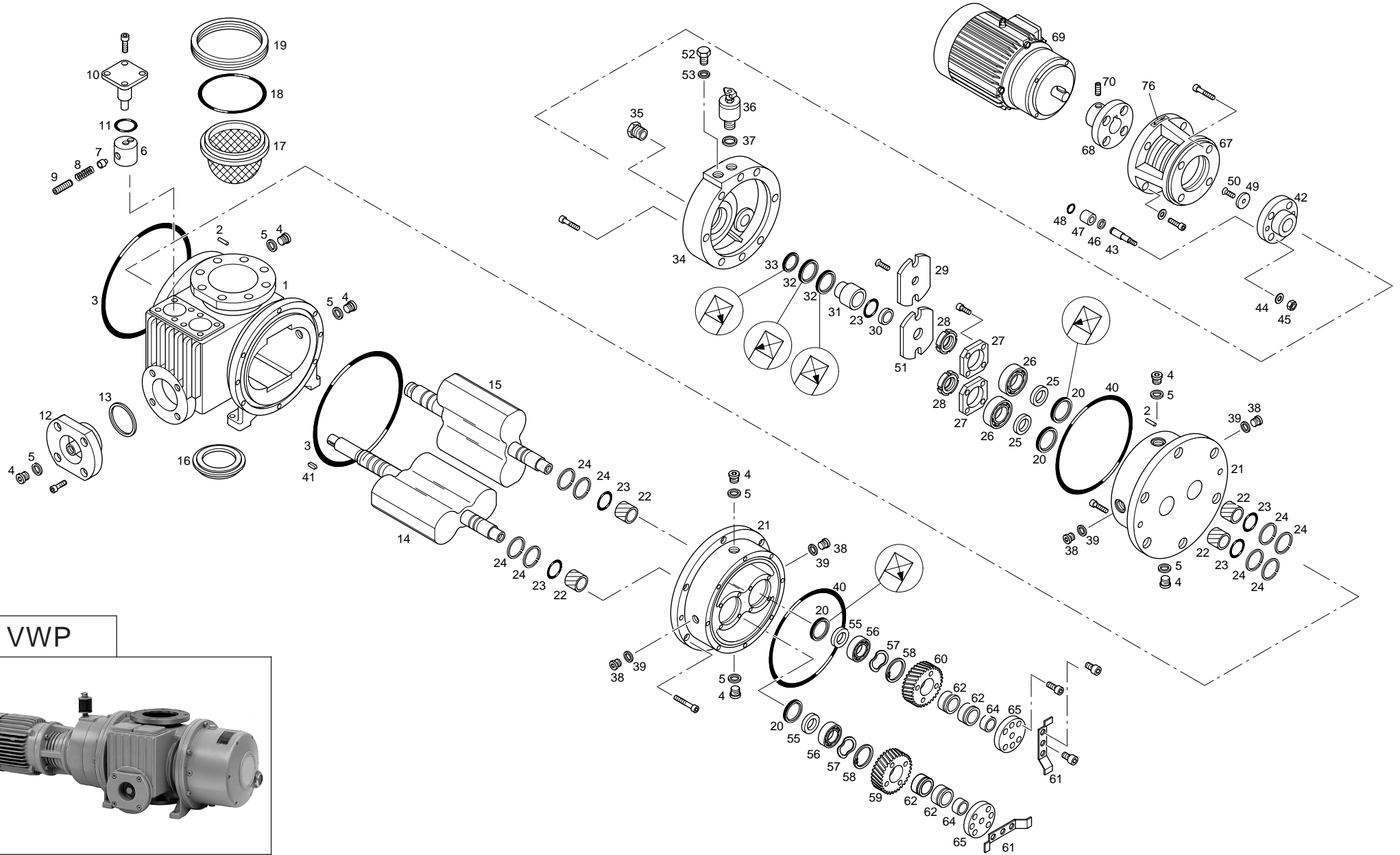

VWP



E 199

1.6.98

	Grundeinheit	Basic unit	Unité de base	Elemento base					
1	Gehäuse	Housing	Corps	Corpo pompa	43	Kupplungsbolzen	Coupling bolt	Plot d'accouplement	Perno del giunto
2	Zylinderstift	Dowel pin	Goujon cylindrique	Spina cilindrica	44	Scheibe	Disc	Rondelle	Disco
3	D O-Ring	O-Ring	Joint torique	O-Ring	45	Sechskantmutter	Hexhead screw	Ecrou six pans	Dado con testa esagonale
4	Verschlußschraube G 3/8	Lock plug	Bouchon obturateur	Vite di chiusura	46	Distanzring	Spacer ring	Rondelle entre-toise	Anello distanziatore
5	D O-Ring	O-Ring	Joint torique	O-Ring	47	V Kupplungsgummi	Coupling rubber	Caoutchouc d'accouplém.	Gommino del giunto
6	Ventilkörper	Valve body	Corps valve	Corpo valvola	48	V Sicherungsring	Lock ring	Circlip	Anello di sicurezza
7	V Bremsnippel	Friction pin	Broche à friction	Nipplo frenate	49	Scheibe	Disc	Rondelle	Disco
8	Druckfeder	Spring	Ressort	Molla a pressione	50	Senkschraube	Countersunk screw	Vis à tête conique	Vite a testa svasata
9	Gewindestift	Threaded pin	Vis pointeau	Spina filettata	51	Schleuderscheibe	Flinger	Disque centrifuge	Disco centrifugo
10	Ventildeckel	Valve cover	Couvercle valve	Coperchio della valvola	52	Sechskantschraube	Hexagon head screw	Vis six pans	Vite con testa esagonale
11	D O-Ring	O-Ring	Joint torique	O-Ring	53	D Dichtring	Sealing ring	Anneau d'étanchéité	Anello guarnizione
12	Flansch	Flange	Bride	Flangia		Anbauteile 'B	Assembly parts 'B	Eléments de montage 'B	Elementi di montaggio 'B
13	D O-Ring	O-Ring	Joint torique	O-Ring	55	Distanzscheibe B	Spacer shim	Rondelle entre-toise	Disco distanziatore
14	Drehkolben 'treibend	Rotary piston 'driving	Piston rotatif 'moteur	Pistone rotante 'trainanto	56	V Rielenkugellager	Deep groove ball bearing	Roulement aiguille	Cuscinetto a sfera
15	Drehkolben 'getrieben	Rotary piston 'driven	Piston rotatif 'entraîné	Pistone rotante 'azionamento	57	V Kugellagerausgleichscheibe	Ball bearing shim	Rondelle rappel de roulement	Anello di rasamento
16	D Dichtring DN 100	Sealing ring	Anneau d'étanchéité	Anello guarnizione	58	V Sicherungsring	Lock ring	Circlip	Anello di sicurezza
17	Schutzsieb	Protection mesh	Crépine protection	Reticella di protezione	59	Zahnrad 'treibend	Gear wheel 'driving	Roue dentée 'moteur	Ruota dentata 'trainanto
18	D O-Ring	O-Ring	Joint torique	O-Ring	60	Zahnrad 'getrieben	Gear wheel 'driven	Roue dentée 'entraîné	Ruota dentata 'azionamento
19	Außenring DN 100	Outside ring	Anneau extérieur	Anello esterno	61	Spritzblech	Splash sheet	Tôle pulvérisateur	Disco spruzzatore
	Anbauteile 'A + B	Assembly parts 'A + B	Eléments de montage 'A + B	Elementi di montaggio 'A + B	62	Konus-Spannelement	Conical-clamping element	Elément tendeur étoupe	Elemento di serraggio cavo
20	D Wellendichtring	Shaft seal	Joint d'arbre	Anello di tenuta sull' albero	63	Abschlußdeckel	End cover	Couvercle	Coperchio di chiusura
21	Gehäusedeckel	Housing cover	Couvercle de corps	Coperchio corpo pompa	64	Spannring	Clamping ring	Bague tendeur	Anello di serraggio
22	V INA-Innenring	INA-sleeve	Bague calibrée	Anello INA	65	Spannscheibe	Spring washer	Rondelle tendeur	Disco di fissaggio
23	D O-Ring	O-Ring	Joint torique	O-Ring		Antrieb	Drive	Entraînement	Azionamento
24	V Kolbenring	Piston ring	Bague de piston	Anello pistone	67	Motorflansch	Motor flange	Bride moteur	Flangia motore
35	V Sechskant-Ölauge	Hex-oil sight glass	Voyant d'huile six pans	Spia livello olio esagonale	68	Kupplungshälfte treibend	Coupling half driving	Demi-accouplement moteur	Semigiunto lato motore
38	Verschlußschraube G 1/8	Lock plug	Bouchon obturateur	Vite di chiusura	69	Motor	Motor	Moteur	Motore
39	D Dichtring	Sealing ring	Anneau d'étanchéité	Anello guarnizione	70	Gewindestift	Threaded pin	Vis pointeau	Spina filettata
40	D O-Ring	O-Ring	Joint torique	O-Ring		Schilder	Labels	Plaques signalétiques	Targhette
25	Distanzscheibe A	Spacer shim	Rondelle entre-toise	Disco distanziatore	75	Datenschild	Data plate	Etiquette caractéristique	Targhetta dati
26	V Schrägkugellager	Angular ball bearing	Roulement rouleaux portée obli.	Cuscinetto a rulli	76	Pfeilschild	Direction arrow	Sens de rotation	Freccia senso di rotazione
27	Spannscheibe	Spring washer	Rondelle tendeur	Disco di fissaggio	77	Ölempfehlungsschild	Oil type plate	Plaquette recom. d'huiles	Targhetta oli consigliati
28	Nutmutter	Groove nut	Ecrou mortaise	Dado cilindrico ad intagli					
29	Schleuderscheibe	Flinger	Disque centrifuge	Disco centrifugo					
30	Distanzring	Spacer ring	Rondelle entre-toise	Anello distanziatore					
31	Laufbuchse	Wearing sleeve	Coussinet	Boccola di scorrimento					
32	D Wellendichtring	Shaft seal	Joint d'arbre	Anello di tenuta sull' albero					
33	D Wellendichtring	Shaft seal	Joint d'arbre	Anello di tenuta sull' albero					
34	Zwischenflansch	Intermediate flange	Bride intermediaire	Flangia intermedia					
36	Öler	Oiler	Graisser	Lubrificatore					
37	D Dichtring	Sealing ring	Anneau d'étanchéité	Anello guarnizione					
41	Paßfeder	Key	Clavette	Chiavetta					
42	Kupplung getrieben	Coupling driven	Accouplement entraîneur	Giunto lato pompa					

Bei Bestellungen folgendes angeben: Typ, Fabrikations-Nr., Positions-Nr., Motor (kW, V, Hz)

To order please indicate: model, serial-no., item-no., motor (kW, V, Hz)

En cas de commande préciser: type d'appareil, no. de position des pièces, moteur (kW, V, Hz)

Nell'ordine indicare: tipo, numero di matricola, numero di posizione dei ricambi, motore (kW, V, Hz)

V = Verschleißteile

V = Wearing parts

V = Pièces d'usure

V = Parti usurabili

D = Dichtungen

D = Seals

D = Joints

D = Guarnizioni

Werner Rietschle GmbH + Co. KG

Postfach 1260 • D-79642 Schopfheim

☎ 07622 / 3 92-0 • Fax 07622 / 39 23 00

e-mail: info@rietschle.com