

**VACTIGER**

VWP



E 199

1.6.98

	<b>Grundeinheit</b>	<b>Basic unit</b>	<b>Unité de base</b>	<b>Elemento base</b>					
1	Gehäuse	Housing	Corps	Corpo pompa	34	Zwischenflansch	Intermediate flange	Bride intermediaire	Flangia intermedia
2	Zylinderstift	Dowel pin	Goujon cylindrique	Spina cilindrica	36	Öler	Oiler	Graisseur	Lubrificatore
3	O-Ring	O-Ring	Joint torique	O-Ring	37	Dichtring	Sealing ring	Anneau d'étanchéité	Anello guarnizione
4	Verschluss-Schraube G 3/8	Lock plug	Bouchon obturateur	Vite di chiusura	41	Passfeder	Key	Clavette	Chiavetta
5	O-Ring	O-Ring	Joint torique	O-Ring	42	Kupplung getrieben	Coupling driven	Accouplement entraîné	Giunto lato pompa
6	Ventilkörper	Valve body	Corps valve	Corpo valvola	43	Kupplungsbolzen	Coupling bolt	Plot d'accouplement	Perno del giunto
7	Bremsnippel	Friction pin	Broche à friction	Nipplo frenate	44	Scheibe	Disc	Rondelle	Disco
8	Druckfeder	Spring	Ressort	Molla a pressione	45	Sechskantmutter	Hexhead screw	Ecrou six pans	Dado con testa esagonale
9	Gewindestift	Threaded pin	Vis pointeau	Spina filettata	46	Distanzring	Spacer ring	Rondelle entre-toise	Anello distanziatore
10	Ventildeckel	Valve cover	Couvercle valve	Coperchio della valvola	47	Kupplungsgummi	Coupling rubber	Caoutchouc d'accouplement	Gommino del giunto
11	O-Ring	O-Ring	Joint torique	O-Ring	48	Sicherungsring	Lock ring	Circlip	Anello di sicurezza
12	Flansch	Flange	Bride	Flangia	49	Scheibe	Disc	Rondelle	Disco
13	O-Ring	O-Ring	Joint torique	O-Ring	50	Senkschraube	Countersunk screw	Vis à tête conique	Vite a testa svasata
14	Drehkolben 'treibend	Rotary piston 'driving	Piston rotatif 'moteur	Pistone rotante 'trainanto	51	Schleuderscheibe	Flinger	Disque centrifuge	Disco centrifugo
15	Drehkolben 'getrieben	Rotary piston 'driven	Piston rotatif 'entraîné	Pistone rotante 'azionamento	52	Sechskantschraube	Hexagon head screw	Vis six pans	Vite con testa esagonale
16	Dichtring DN 100	Sealing ring	Anneau d'étanchéité	Anello guarnizione	53	Dichtring	Sealing ring	Anneau d'étanchéité	Anello guarnizione
17	Schutzsieb	Protection mesh	Crépine protection	Reticella di protezione		<b>Anbauteile 'B</b>	<b>Assembly parts 'B</b>	<b>Eléments de montage 'B</b>	<b>Elementi di montaggio 'B</b>
18	O-Ring	O-Ring	Joint torique	O-Ring	55	Distanzscheibe B	Spacer shim	Rondelle entre-toise	Disco distanziatore
19	Außenring DN 100	Outside ring	Anneau extérieur	Anello esterno	56	Rillenkugellager	Deep groove ball bearing	Roulement aiguille	Cuscinetto a sfera
20	<b>Anbauteile 'A + B</b>	<b>Assembly parts 'A + B</b>	<b>Eléments de montage 'A + B</b>	<b>Elementi di montaggio 'A + B</b>	57	Kugellagerausgleichscheibe	Ball bearing shim	Rondelle rappel de roulement	Anello di rasamento
21	Wellendichtring	Shaft seal	Joint d'arbre	Anello di tenuta sull' albero	58	Sicherungsring	Lock ring	Circlip	Anello di sicurezza
22	Gehäusedeckel	Housing cover	Couvercle de corps	Coperchio corpo pompa	59	Zahnrad 'treibend	Gear wheel 'driving	Roue dentée 'moteur	Ruota dentata 'trainanto
23	INA-Innenring	INA-sleeve	Bague calibrée	Anello INA	60	Zahnrad 'getrieben	Gear wheel 'driven	Roue dentée 'entraîné	Ruota dentata 'azionamento
24	O-Ring	O-Ring	Joint torique	O-Ring	61	Spritzblech	Splash sheet	Tôle pulvérisateur	Disco spruzzatore
25	Kolbenring	Piston ring	Bague de piston	Anello pistone	62	Konus-Spannelement	Conical-clamping element	Elément tendeur étoupe	Elemento di serraggio cavo
26	Sechskant-Ölauge	Hex-oil sight glass	Voyant d'huile six pans	Spia livello olio esagonale	63	Abschlussdeckel	End cover	Couvercle	Coperchio di chiusura
27	Verschluss-Schraube G 1/8	Lock plug	Bouchon obturateur	Vite di chiusura	64	Spannring	Clamping ring	Bague tendeur	Anello di serraggio
28	Dichtring	Sealing ring	Anneau d'étanchéité	Anello guarnizione	65	Spannscheibe	Spring washer	Rondelle tendeur	Disco di fissaggio
29	O-Ring	O-Ring	Joint torique	O-Ring		<b>Antrieb</b>	<b>Drive</b>	<b>Entraînement</b>	<b>Azionamento</b>
30	<b>Anbauteile 'A</b>	<b>Assembly parts 'A</b>	<b>Eléments de montage 'A</b>	<b>Elementi di montaggio 'A</b>	67	Motorflansch	Motor flange	Bride moteur	Flangia motore
31	Distanzscheibe A	Spacer shim	Rondelle entre-toise	Disco distanziatore	68	Kupplungshälfte treibend	Coupling half driving	Demi-accouplement moteur	Semigiunto lato motore
32	Schräggkugellager	Angular ball bearing	Roulement rouleaux portée obli.	Cuscinetto a rulli	69	Motor	Motor	Moteur	Motore
33	Spannscheibe	Spring washer	Rondelle tendeur	Disco di fissaggio	70	Gewindestift	Threaded pin	Vis pointeau	Spina filettata
34	Nutmutter	Groove nut	Ecrou mortaise	Dado cilindrico ad tagli		<b>Schilder</b>	<b>Labels</b>	<b>Plaques signalétiques</b>	<b>Targhette</b>
35	Schleuderscheibe	Flinger	Disque centrifuge	Disco centrifugo	75	Datenschild	Data plate	Etiquette caractéristique	Targhetta dati
36	Distanzring	Spacer ring	Rondelle entre-toise	Anello distanziatore	76	Pfeilschild	Direction arrow	Sens de rotation	Freccia senso di rotazione
37	Laufbuchse	Wearing sleeve	Coussinet	Boccola di scorrimento	77	Ölempfehlungsschild	Oil type plate	Plaquette recom. d'huiles	Targhetta oli consigliati
38	Wellendichtring	Shaft seal	Joint d'arbre	Anello di tenuta sull' albero					
39	Wellendichtring	Shaft seal	Joint d'arbre	Anello di tenuta sull' albero					

**Bei Bestellungen folgendes angeben:** Typ, Fabrikations-Nr., Positions-Nr., Motor (kW, V, Hz)

**To order please indicate:** model, serial-no., item-no., motor (kW, V, Hz)

**En cas de commande préciser:** type d'appareil, no. de position des pièces, moteur (kW, V, Hz)

**Nell'ordine indicare:** tipo, numero di matricola, numero di posizione dei ricambi, motore (kW, V, Hz)

**V** = Verschleißteile

**V** = Wearing parts

**V** = Pièces d'usure

**V** = Parti usurabili

**D** = Dichtungen

**D** = Seals

**D** = Joints

**D** = Guarnizioni

**Gardner Denver Schopfheim GmbH**

Postfach 1260 • 79642 SCHOPFHEIM / GERMANY

Fon +49 7622 / 392-0 • Fax +49 7622 / 392-300

er.de@gardnerdenver.com • www.gd-elmorietschle.com

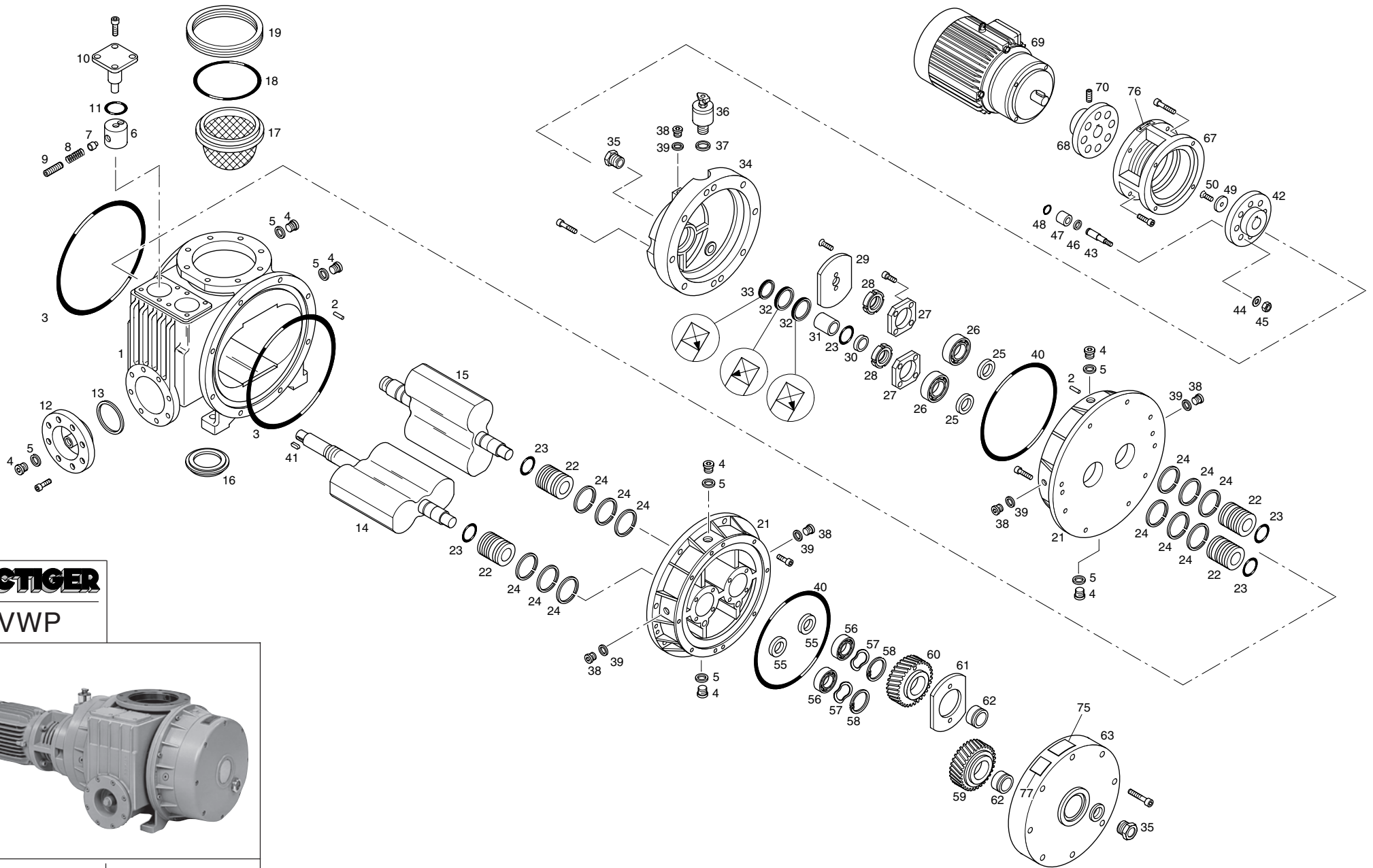

**VACTIGER**

VWP

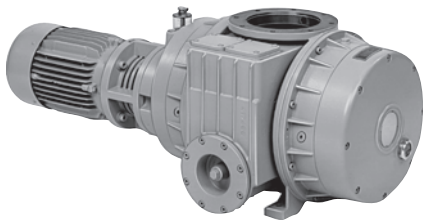

E 200

1.6.98

	<b>Grundeinheit</b>	<b>Basic unit</b>	<b>Unité de base</b>	<b>Elemento base</b>					
1	Gehäuse	Housing	Corps	Corpo pompa	36	Öler	Oiler	Graisseur	Lubrificatore
2	Zylinderstift	Dowel pin	Goujon cylindrique	Spina cilindrata	37	D Dichtring	Sealing ring	Anneau d'étanchéité	Anello guarnizione
3	O-Ring	O-Ring	Joint torique	O-Ring	41	Passfeder	Key	Clavette	Chiavetta
4	D O-Ring	O-Ring	Joint torique	O-Ring	42	Kupplung getrieben	Coupling driven	Accouplement entraîné	Giunto lato pompa
4	Verschluss-Schraube G 3/8	Lock plug	Bouchon obturateur	Vite di chiusura	43	Kupplungsbolzen	Coupling bolt	Plot d'accouplement	Perno del giunto
5	D O-Ring	O-Ring	Joint torique	O-Ring	44	Scheibe	Disc	Rondelle	Disco
6	Ventilkörper	Valve body	Corps valve	Corpo valvola	45	Sechskantmutter	Hexhead screw	Ecrou six pans	Dado con testa esagonale
7	V Bremsnippel	Friction pin	Broche à friction	Nipplo frenate	46	Distanzring	Spacer ring	Rondelle entre-toise	Anello distanziatore
8	Druckfeder	Spring	Ressort	Molla a pressione	47	V Kupplungsgummi	Coupling rubber	Caoutchouc d'accouplement	Gommino del giunto
9	Gewindestift	Threaded pin	Vis pointeau	Spina filettata	48	V Sicherungsring	Lock ring	Circlip	Anello di sicurezza
10	Ventildeckel	Valve cover	Couvercle valve	Coperchio della valvola	49	Scheibe	Disc	Rondelle	Disco
11	D O-Ring	O-Ring	Joint torique	O-Ring	50	Senkschraube	Countersunk screw	Vis à tête conique	Vite a testa svasata
12	Flansch	Flange	Bride	Flangia		<b>Anbauteile 'B'</b>	<b>Assembly parts 'B'</b>	<b>Eléments de montage 'B'</b>	<b>Elementi di montaggio 'B'</b>
13	D O-Ring	O-Ring	Joint torique	O-Ring	55	Distanzscheibe B	Spacer shim	Rondelle entre-toise	Disco distanziatore
14	Drehkolben 'treibend	Rotary piston 'driving	Piston rotatif 'moteur	Pistone rotante 'trainante	56	V Rillenkugellager	Deep groove ball bearing	Roulement aiguille	Cuscinetto a sfera
15	Drehkolben 'getrieben	Rotary piston 'driven	Piston rotatif 'entraîné	Pistone rotante 'azionamento	57	V Kugellagerausgleichscheibe	Ball bearing shim	Rondelle rappel de roulement	Anello di rasamento
16	D Dichtring DN 100	Sealing ring	Anneau d'étanchéité	Anello guarnizione	58	V Sicherungsring	Lock ring	Circlip	Anello di sicurezza
17	Schutzsieb	Protection mesh	Crépine protection	Reticella di protezione	59	Zahnrad 'treibend	Gear wheel 'driving	Roue dentée 'moteur	Ruota dentata 'trainante
18	D O-Ring	O-Ring	Joint torique	O-Ring	60	Zahnrad 'getrieben	Gear wheel 'driven	Roue dentée 'entraîné	Ruota dentata 'azionamento
19	Außenring DN 160	Outside ring	Anneau extérieur	Anello esterno	61	Schleuderscheibe B	Flinger	Disque centrifuge	Disco centrifugo
	<b>Anbauteile 'A + B'</b>	<b>Assembly parts 'A + B'</b>	<b>Eléments de montage 'A + B'</b>	<b>Elementi di montaggio 'A + B'</b>	62	Konus-Spannelement	Conical-clamping element	Élément tendeur étoupe	Elemento di serraggio cavo
21	Gehäusedeckel	Housing cover	Couvercle de corps	Coperchio corpo pompa	63	Abschlussdeckel	End cover	Couvercle	Coperchio di chiusura
22	Ringträger	Support ring	Support anneau	Trave circolare		<b>Antrieb</b>	<b>Drive</b>	<b>Entraînement</b>	<b>Azionamento</b>
23	D O-Ring	O-Ring	Joint torique	O-Ring	67	Motorflansch	Motor flange	Bride moteur	Flangia motore
24	V Kolbenring	Piston ring	Bague de piston	Anello pistone	68	Kupplungshälfte treibend	Coupling half driving	Demi-accouplement moteur	Semigiunto lato motore
35	V Sechskant-Ölauge	Hex-oil sight glass	Voyant d'huile six pans	Spia livello olio esagonale	69	Motor	Motor	Moteur	Motore
38	Verschluss-Schraube G 1/8	Lock plug	Bouchon obturateur	Vite di chiusura	70	Gewindestift	Threaded pin	Vis pointeau	Spina filettata
39	D Dichtring	Sealing ring	Anneau d'étanchéité	Anello guarnizione		<b>Schilder</b>	<b>Labels</b>	<b>Plaques signalétiques</b>	<b>Targhette</b>
40	D O-Ring	O-Ring	Joint torique	O-Ring	75	Datenschild	Data plate	Étiquette caractéristique	Targhetta dati
	<b>Anbauteile 'A'</b>	<b>Assembly parts 'A'</b>	<b>Eléments de montage 'A'</b>	<b>Elementi di montaggio 'A'</b>	76	Pfeilschild	Direction arrow	Sens de rotation	Freccia senso di rotazione
25	Distanzscheibe A	Spacer shim	Rondelle entre-toise	Disco distanziatore	77	Ölempfehlungsschild	Oil type plate	Plaquette recom. d'huiles	Targhetta oli consigliati
26	V Schrägkugellager	Angular ball bearing	Roulement rouleaux portée obli.	Cuscinetto a rulli					
27	Spannscheibe	Spring washer	Rondelle tendeur	Disco di fissaggio					
28	Nutmutter	Groove nut	Ecrou mortaise	Dado cilindrico ad intagli					
29	Schleuderscheibe A	Flinger	Disque centrifuge	Disco centrifugo					
30	Distanzring	Spacer ring	Rondelle entre-toise	Anello distanziatore					
31	Laufbuchse	Wearing sleeve	Coussinet	Boccola di scorrimento					
32	D Wellendichtring	Shaft seal	Joint d'arbre	Anello di tenuta sull' albero					
33	D Wellendichtring	Shaft seal	Joint d'arbre	Anello di tenuta sull' albero					
34	Zwischenflansch	Intermediate flange	Bride intermédiaire	Flangia intermedia					

**Bei Bestellungen folgendes angeben:** Typ, Fabrikations-Nr., Positions-Nr., Motor (kW, V, Hz)

**To order please indicate:** model, serial-no., item-no., motor (kW, V, Hz)

**En cas de commande préciser:** type d'appareil, no. de position des pièces, moteur (kW, V, Hz)

**Nell'ordine indicare:** tipo, numero di matricola, numero di posizione dei ricambi, motore (kW, V, Hz)

**V** = Verschleißteile

**V** = Wearing parts

**V** = Pièces d'usure

**V** = Parti usurabili

**D** = Dichtungen

**D** = Seals

**D** = Joints

**D** = Guarnizioni

**Gardner Denver Schopfheim GmbH**

Postfach 1260 • 79642 SCHOPFHEIM / GERMANY

Fon +49 7622 / 392-0 • Fax +49 7622 / 392-300

er.de@gardnerdenver.com • www.gd-elmorietschle.com

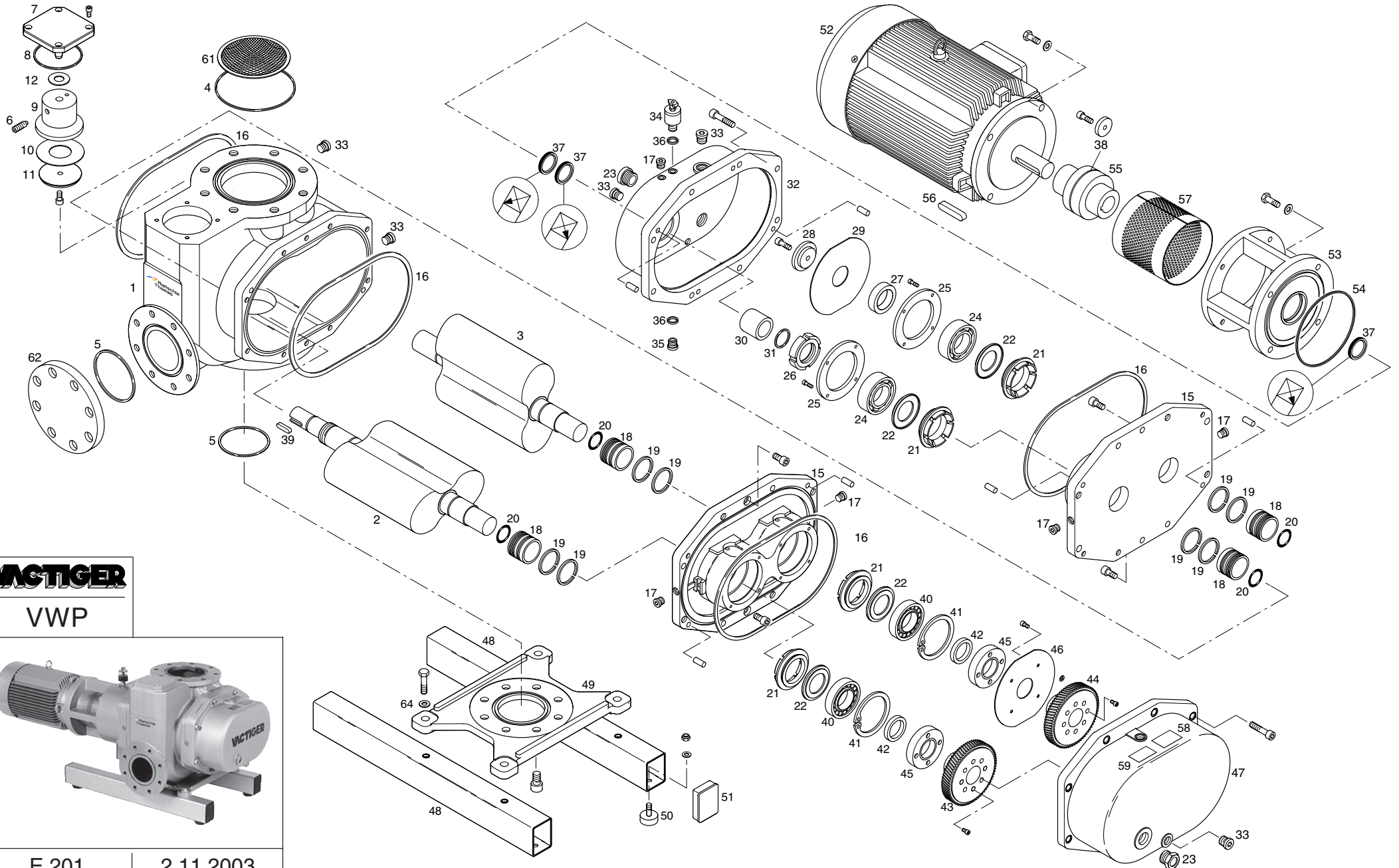

**VACTIGER**

VWP

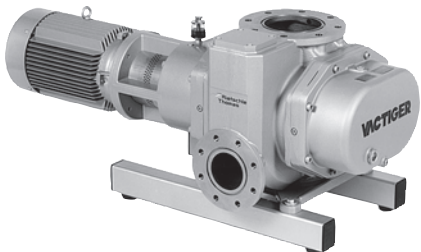



	<b>Grundeinheit</b>	<b>Basic unit</b>	<b>Unité de base</b>	<b>Elemento base</b>						
1	Gehäuse	Housing	Corps	Corpo pompa	38		Scheibe	Disc	Rondelle	Disco
2	Drehkolben 'treibend	Rotary piston 'driving	Piston rotatif 'moteur	Pistone rotante 'trainanto	39		Passfeder	Key	Clavette	Chiavetta
3	Drehkolben 'getrieben	Rotary piston 'driven	Piston rotatif 'entraîné	Pistone rotante 'azionamento	40	V	<b>Anbauteile 'B</b>	<b>Assembly parts 'B</b>	<b>Eléments de montage 'B</b>	<b>Elementi di montaggio 'B</b>
4	D O-Ring	O-Ring	Joint torique	O-Ring	41	V	Zylinder-Rollenlager	Cylinder roller bearing	Roulement rouleaux cylindr.	Cuscinetto a rulli
5	D O-Ring	O-Ring	Joint torique	O-Ring	42		Sicherungsring	Lock ring	Circlip	Anello di sicurezza
6	Gewindestift	Threaded pin	Vis pointeau	Spina filettata	43		Distanzring	Spacer ring	Rondelle entretoise	Anello distanziatore
7	Ventildeckel	Valve cover	Couvercle valve	Coperchio della valvola	44		Zahnrad 'treibend	Gear wheel 'driving	Roue dentée 'moteur	Ruota dentata 'trainanto
8	D O-Ring	O-Ring	Joint torique	O-Ring	45		Zahnrad 'getrieben	Gear wheel 'driven	Roue dentée 'entraîné	Ruota dentata 'azionamento
9	Ventilkörper	Valve body	Corps valve	Corpo valvola	46		Konus-Spannelement	Conical-clamping element	Elément tendeur étoupe	Elemento di serraggio cavo
10	Scheibe	Disc	Rondelle	Disco	47		Schleuderscheibe B	Flinger	Disque centrifuge	Disco centrifugo
11	Scheibe	Disc	Rondelle	Disco			Abschlussdeckel	End cover	Couvercle	Coperchio di chiusura
12	Scheibe	Disc	Rondelle	Disco			<b>Antrieb</b>	<b>Drive</b>	<b>Entraînement</b>	<b>Azionamento</b>
33	Verschluss-Schraube G 3/8	Lock plug	Bouchon obturateur	Vite di chiusura	52		Motor	Motor	Moteur	Motore
	<b>Anbauteile 'A + B</b>	<b>Assembly parts 'A + B</b>	<b>Eléments de montage 'A + B</b>	<b>Elementi di montaggio 'A + B</b>	53		Motorflansch	Motor flange	Bride moteur	Flangia motore
15	Gehäusedeckel	Housing cover	Couvercle de corps	Coperchio corpo pompa	54	D	O-Ring	O-Ring	Joint torique	O-Ring
16	D O-Ring	O-Ring	Joint torique	O-Ring	55		Kupplung	Coupling	Accouplement	Giunto
17	Verschluss-Schraube G 1/8	Lock plug	Bouchon obturateur	Vite di chiusura	56		Passfeder	Key	Clavette	Chiavetta
18	Ringträger	Support ring	Support anneau	Trave circolare	57		Schutzhaube	Protection cover	Capot protection	Calotta di protezione
19	V Kolbenring	Piston ring	Bague de piston	Anello pistone	58		<b>Schilder</b>	<b>Labels</b>	<b>Plaques signalétiques</b>	<b>Targhette</b>
20	D O-Ring	O-Ring	Joint torique	O-Ring	59		Datenschild	Data plate	Etiquette caractéristique	Targhetta dati
21	Labyrinthring ' 1	Labyrinth ring ' 1	Anneau labyrinthe ' 1	Anello di labirinto ' 1			Ölempfehlungsschild	Oil type plate	Plaquette recom. d'huiles	Targhetta oli consigliati
22	Labyrinthring ' 2	Labyrinth ring ' 2	Anneau labyrinthe ' 2	Anello di labirinto ' 2			<b>Zubehör</b>	<b>Optional extras</b>	<b>Accessoires</b>	<b>Accessori</b>
23	V Sechskant-Ölauge	Hex-oil sight glass	Voyant d'huile six pans	Spia livello olio esagonale	48		Fuß	Foot	Socle	Piedistallo
	<b>Anbauteile 'A</b>	<b>Assembly parts 'A</b>	<b>Eléments de montage 'A</b>	<b>Elementi di montaggio 'A</b>	49		Fuß-Flansch	Foot flange	Support bride	Piedistallo flangia
24	V Schrägkugellager	Angular ball bearing	Roulement rouleaux portée obl.	Cuscinetto a rulli	50		Schwingmetallpuffer	Rubber foot	Silent bloc	Piedini antivibranti
25	Spannscheibe	Spring washer	Rondelle tendeur	Disco di fissaggio	51		Kappe	Cap	Chapeau	Tappo
26	Nutmutter	Groove nut	Ecrou mortaise	Dado cilindrico ad intagli	61		Sieb	Mesh	Tamis	Reticella
27	Distanzring	Spacer ring	Rondelle entre-toise	Anello distanziatore	62		Blindflansch	Blank flange	Bride aveugle	Flangia cieca
28	Scheibe	Disc	Rondelle	Disco	64		Scheibe	Disc	Rondelle	Disco
29	Schleuderscheibe A	Flinger	Disque centrifuge	Disco centrifugo						
30	Laufbuchse	Wearing sleeve	Coussinet	Boccola di scorrimento						
31	D O-Ring	O-Ring	Joint torique	O-Ring						
32	Zwischenflansch	Intermediate flange	Bride intermediaire	Flangia intermedia						
33	Verschluss-Schraube G 3/8	Lock plug	Bouchon obturateur	Vite di chiusura						
34	Ölstands-Kontrollbehälter	Oil level control pot	Réservoir contrôle niveau d'huile	Vaso di controllo dell'olio						
35	Verschluss-Schraube G 1/4	Lock plug	Bouchon obturateur	Vite di chiusura						
36	D Dichtring	Sealing ring	Anneau d'étanchéité	Anello di tenuta						
37	D Wellendichtring	Shaft seal	Joint d'arbre	Anello di tenuta sull' albero						

**Bei Bestellungen folgendes angeben:** Typ, Fabrikations-Nr., Positions-Nr., Motor (kW, V, Hz)  
**To order please indicate:** model, serial-no., item-no., motor (kW, V, Hz)  
**En cas de commande préciser:** type d'appareil, no. de position des pièces, moteur (kW, V, Hz)  
**Nell'ordine indicare:** tipo, numero di matricola, numero di posizione dei ricambi, motore (kW, V, Hz)

**V** = Verschleißteile  
**V** = Wearing parts  
**V** = Pièces d'usure  
**V** = Parti usurabili  
**D** = Dichtungen  
**D** = Seals  
**D** = Joints  
**D** = Guarnizioni

**Gardner Denver Schopfheim GmbH**  
 Postfach 1260 • 79642 SCHOPFHEIM / GERMANY  
 Fon +49 7622 / 392-0 • Fax +49 7622 / 392-300  
 er.de@gardnerdenver.com • www.gd-elmorietschle.com