

VGA 4 → VGA 20 • VGC 4 → VGC 15

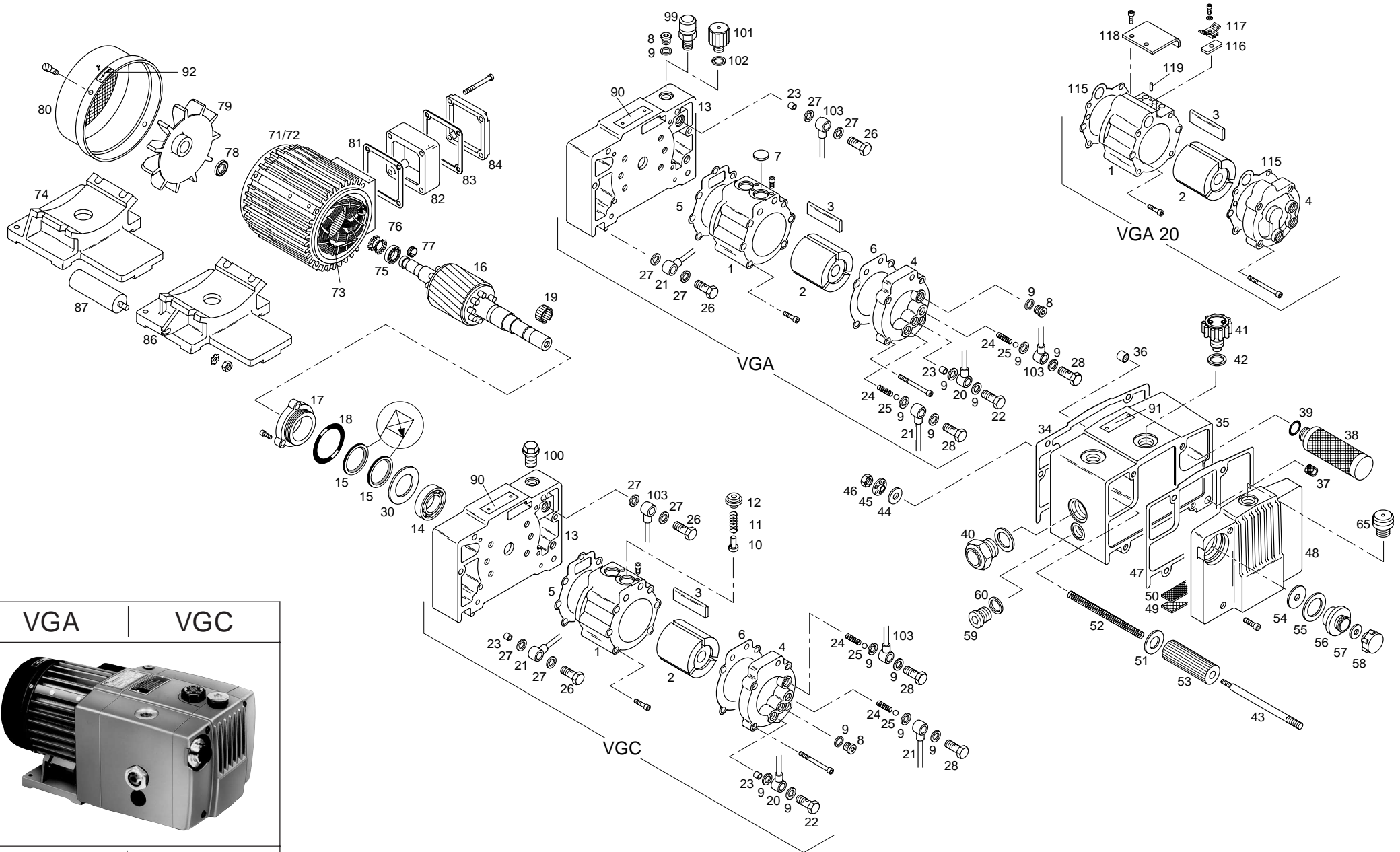

VGA

VGC



E 146

2.11.98

	Grundeinheit	Basic unit	Unité de base	Unità base	50	V	Sieb	Mesh	Tamis	Reticella
1	Gehäuse	Housing	Corps	Carcassa	51	D	Dichtring	Sealing ring	Anneau d'étanchéité	Anello guarnizione
2	Rotor	Rotor	Rotor	Rotore	52		Druckfeder	Spring	Ressort	Molla
3	V Lamelle	Blade	Palette	Paletta	53	V	Micro-Top-Patrone	Filter cartridge	Cartouche filtre micronique	Cartuccia filtrante microfine
4	Gehäusedeckel	Housing cover	Couvercle de corps	Coperchio carcassa	54	D	Dichtring	Sealing ring	Anneau d'étanchéité	Anello guarnizione
5	D Dichtung (Packung)	Gasket	Joint	Guarnizione	55	D	Dichtring	Sealing ring	Anneau d'étanchéité	Anello guarnizione
6	D Dichtung	Gasket	Joint	Guarnizione	56		Filterdeckel	Filter cover	Couvercle filtre	Coperchio del filtro
7	Deckel (VGA 4 - 15)	Cover	Couvercle	Coperchio	57	D	Dichtring	Sealing ring	Anneau d'étanchéité	Anello guarnizione
8	Verschlußschr. M10 x 1	Lock plug M10 x 1	Vis d'obturation M10 x 1	Vite di chiusura M10 x 1	58		Filterschraubknopf	Filter knob	Tête molette	Pomello a vite
9	D Dichtring	Sealing ring	Anneau d'étanchéité	Anello guarnizione	59		Verschlußsschraube G ^{3/8}	Lock plug G ^{3/8}	Bouchon obturateur G ^{3/8}	Vite chiusura G ^{3/8}
10	Ventilteller (VGC 4 - 15)	Valve plate	Disque valve	Disco della valvola	60	D	Dichtring	Sealing ring	Anneau d'étanchéité	Anello guarnizione
11	Druckfeder (VGC 4 - 15)	Spring	Ressort	Molla	65		Geräuschdämpfer	Silencer	Silencieux	Silenziatore
12	Ventilführung (VGC 4 - 15)	Valve guide	Guide valve	Perno valvola			Antrieb	Drive	Entraînement	Azionamento
	Anschlußdeckel	Connection cover	Couvercle raccordement	Coperchio di collegamento	71		Motorgehäuse komplett	Motor housing complete	Enveloppe et stator	Carcassa motore completa
13	Anschlußdeckel	Connection cover	Couvercle raccordement	Coperchio di collegamento	72		Motorgehäuse (Einzelteil)	Motor housing (single part)	Enveloppe stator	Carcassa motore (singola)
14	V Rillenkugellager	Deep groove ball bearing	Roulement à billes	Cuscinetto a sfera	73		Stator	Stator	Stator	Statore
15	D Wellendichtring	Shaft seal	Joint d'arbre	Anello guarnizione albero	74		Fuß (3 ~)	Foot (3 ~)	Socle (3 ~)	Piedistallo (3 ~)
16	Motorwelle	Motor shaft	Arbre moteur	Albero motore	75	V	Rillenkugellager	Deep groove ball bearing	Roulement à billes	Cuscinetto a sfera
17	Lagerdeckel	Bearing cover	Couvercle pallier	Coperchio cuscinetti	76	V	Sternfeder	Spring	Rondelle de rappel	Rosetta elastica
18	D O-Ring	O-Ring	Joint torique	O-Ring	77	V	Toleranzring	Tolerance ring	Entretoise	Anello di tolleranza
19	V Toleranzring	Tolerance ring	Entretoise	Anello di tolleranza	78	D	INA-Dichtring	INA-seal ring	Joint d'arbre INA	Anello di tenuta INA
30	Scheibe	Disc	Rondelle	Disco	79		Ventilator	Fan	Ventilateur	Ventilatore
	Rohrleitungen	Pipe work	Tuyauteries	Tabazioni	80		Schutzhaube	Protection cover	Capot protection	Calotta di protezione
20	Ansaugung	Suction	Aspiration	Aspirazione	81		Dichtung	Gasket	Joint	Guarnizione
21	Rücksaugung	Resuction	Réaspiration	Tubo recupero olio	82		Klemmkasten-Unterteil	Terminal box	Carter boîte à bornes	Base morsettiere
22	Hohlschraube M10 x 1	Banjo bolt M10 x 1	Vis creuse M10 x 1	Vite foratae M10 x 1	83		Dichtung	Gasket	Joint	Guarnizione
23	Einsatzdüse	Nozzle	Douille calibrée	Ugello	84		Klemmkasten-Deckel	Terminal box cover	Couvercle boîte de bornes	Coperchio morsettiere
24	Druckfeder	Spring	Ressort	Molla	86		Fuß (1 ~)	Foot (1 ~)	Socle (1 ~)	Piedistallo (1 ~)
25	Kugel	Ball	Bille	Sfera	87		Kondensator (1 ~)	Capacitor (1 ~)	Condensateur (1 ~)	Condensatore (1 ~)
26	Hohlschraube M8 x 1	Banjo bolt M8 x 1	Vis creuse M8 x 1	Vite foratae M8 x 1			Schilder	Labels	Plaques signalétiques	Targhette
27	D Dichtring	Sealing ring	Anneau d'étanchéité	Anello guarnizione	90		Datenschild	Data plate	Etiquette caractéristique	Targhetta dati
28	Hohlschraube M10 x 1	Banjo bolt M10 x 1	Vis creuse M10 x 1	Vite foratae M10 x 1	91		Ölempfehlungsschild	Oil type plate	Plaquette recommand. d'huiles	Targhetta oli consigliati
103	Frischlufzufuhr	Fresh air supply	Amener air frais	Alimentazione aria esterna	92		Pfeilschild	Direction arrow	Sens de rotation	Targhetta con freccia
	Ölbehälter	Oil tank	Réservoir d'huile	Serbatoio olio			Gasballast	Gas ballast	Lest d'air	Valvola zavorra gas
34	D Dichtung	Gasket	Joint	Guarnizione	99		(bei VGA wahlweise)	(at VGA optional)	(option VGA)	(opzione VGA)
35	Ölbehälter	Oil tank	Réservoir d'huile	Serbatoio olio	100		Belüftungsfiter (VGA 4 - 15)	Vent filter	Filtre d'aération	Filtro d'aerazione
36	Einsatzdüse	Nozzle	Douille calibrée	Ugello	101		Gasballastschraube (VGC)	Gas ballast screw	Vis lest d'air	Vite zavorra gas
37	V Ansaugsieb	Suction mesh	Crépine d'aspiration	Reticella in aspirazione	102	D	Gasballastventil (VGA 20)	Gasballast valve	Clapet lest d'air	Valvola zavorra gas
38	V Luftentölement	Oil separator element	Elément déshuileur	Elemento separatore aria			Dichtring (VGA 20)	Sealing ring	Anneau d'étanchéité	Anello di tenuta
39	D O-Ring	O-Ring	Joint torique	O-Ring			Grundeinheit (VGA 20)	Basic unit (VGA 20)	Unité de base (VGA 20)	Unità base (VGA 20)
40	V Sechskant-Ölauge	Hex-oil sight glass	Voyant d'huile	Spia olio esagonale	1		Gehäuse	Housing	Corps	Carcassa
41	Öleinfüllknopf	Oil filler plug	Bouchon remplissage d'huiles	Punto riempimento olio	2		Rotor	Rotor	Rotor	Rotore
42	D Dichtring	Sealing ring	Joint	Anello guarnizione	3	V	Lamelle	Blade	Palette	Paletta
43	Filterbolzen	Filter bolt	Plot filtre	Perno del filtro	4		Gehäusedeckel	Housing cover	Couvercle de corps	Coperchio carcassa
44	D Ventilscheibe	Valve disc	Rondelle valve	Rondella della valvola	115	D	Dichtung (Packung)	Gasket	Joint	Guarnizione
45	Ventilteller	Valve plate	Disque valve	Disco della valvola	116		Ventilplatte	Valve plate	Plaque valve	Piastra della valvola
46	Sechskantmutter	Hexhead screw	Ecrou six pans	Dado con testa esagonale	117		Bügel	Bow	Etrier	Supporto
47	D Dichtung	Gasket	Joint	Guarnizione	118		Leitblech	Guiding plate	Tôle guide	Deflettore
48	Ölbehälterdeckel	Oil tank cover	Couvercle réservoir d'huile	Coperchio serbatoio olio	119		Zylinderstift	Dowel pin	Goujon cylindrique	Spina cilindrica
49	V Trenngitter	Grill	Grille séparatrice	Griglia di separazione						

Bei Bestellungen folgendes angeben: Typ, Fabrikations-Nr., Positions-Nr., Motor (kW, V, Hz)

To order please indicate: model, serial-no., item-no., motor (kW, V, Hz)

En cas de commande préciser: type d'appareil, no. de position des pièces, moteur (kW, V, Hz)

Nell'ordine indicare: tipo, numero di matricola, numero di posizione dei ricambi, motore (kW, V, Hz)

V = Verschleißteile

V = Wearing parts

V = Pièces d'usure

V = Parti usurabili

D = Dichtungen

D = Seals

D = Joints

D = Guarnizioni

Werner Rietschle GmbH + Co. KG

Postfach 1260 • D-79642 Schopfheim

☎ 07622 / 392-0 • Fax 07622 / 392300

e-mail: info@rietschle.com