



SKP

SKP 253 20

SKP 302 20

SKP 358 26

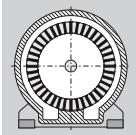

Seitenkanal-
Vakuumpumpen

Side channel
vacuum pumps

Turbine latérale
vide

Pompe per vuoto
a canali laterali

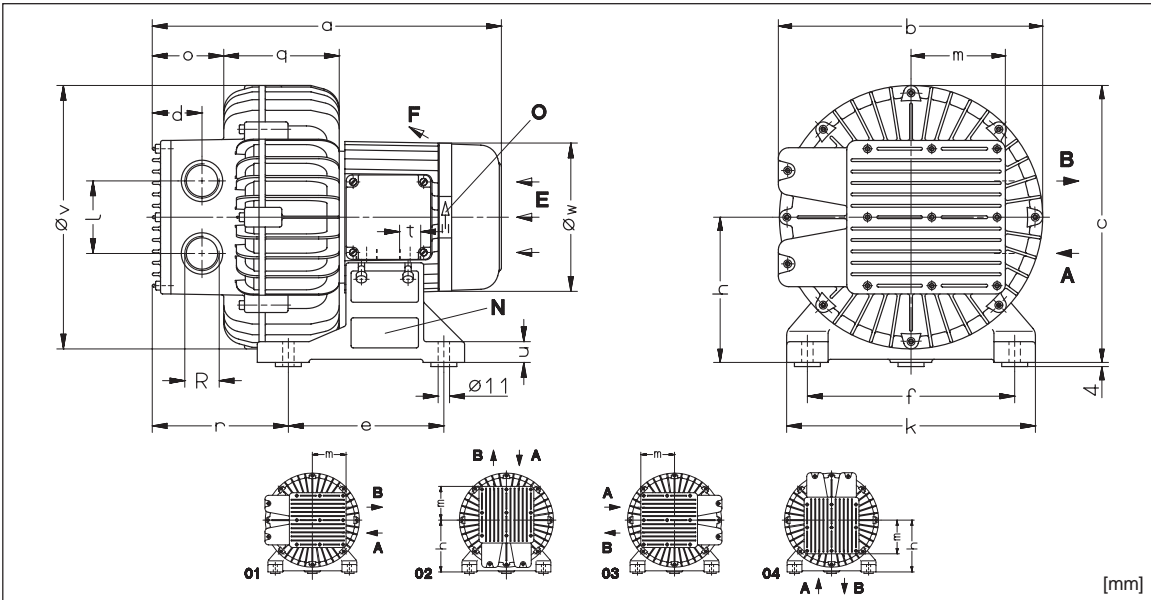

01-04	Anschlußstellungen	Connection positions	Positions raccordement	Posizioni di collegamenti
02	Normal-Ausführung	Standard version	Exécution standard	Esecuzione standard
A	Vakuum-Anschluß	Vacuum connection	Raccord du vide	Attacco vuoto
B	Abluft-Anschluß	Exhaust air connection	Raccord air d'échappement	Raccordo aria di scarico
E	Kühlluft-Eintritt	Cooling air entry	Entrée air refroidissement	Entrata aria di raffreddamento
F	Kühlluft-Austritt	Cooling air exit	Sortie air refroidissement	Uscita aria di raffreddamento
N	Datenschild	Data plate	Etiquette caractéristique	Targhetta dati
O	Drehrichtungsschild	Direction of rotation	Flèche sens rotation	Targhetta senso rotazione

SKP	253 20		302 20		358 26		
[mm]	a	3~ 375 1~ 375	394 416	429	480	503	511
	b	282		344	409		
	c	302		355	413		
	d / e	48 / 150		64 / 160	69 / 230		
	f / h	200 / 160		235 / 185	320 / 220		
	k / l	240 / 78		280 / 90	380 / 120		
	m	102		121	143		
	o	74		104	107		
	q	126		140	158		
	r	150		188	155		174
	t	M 20 x 1,5		M 25 x 1,5	M 25 x 1,5		M 32 x 1,5
	u	16		25	35		
	øv	284		340	385		
	øw	143		177	175		212
	R	G 1 1/4		G 2	G 2		

ZRK		32 (03)		50 (03)	50 (03)		
ZBS	50 Hz	32		40	65	65	40
	60 Hz	40	32	40	-	65	40
ZVF		50 (52)		50 (53)	50 (53)		
ZGD		32 (06)		50 (06)	50 (06)		
ZFP		216 (07)		216 (01)	216 (01)		
ZMS (3~)	50 Hz	40/24	60/24	100/40	100/40	100/60	160/100
	60 Hz	40/24	60/40	100/60	-	160/100	160/100
ZMS (1~)	50 Hz	60	100	-	-		
	60 Hz	#	100	-	-		
ZWS		61 (03)		83 (01)	83 (02)		

ZRK	Zubehör	Optional extras	Accessoires	Accessori
ZBS	Rückschlagventil	Non-return valve	Clapet anti-retour	Valvola di non ritorno
ZVF	Saug-Begrenzungsventil	Vacuum limitation valve	Limiteur de dépression	Valvola limitatrice di aspirazione
ZGD	Vakuumdichter Ansaugfilter	Vacuum tight suction filter	Filtre d'aspiration étanche	Filtro aspirazione ermetico
ZFP	Zusätzlicher Schalldämpfer	Additional silencer	Silencieux complémentaire	Silenziatore supplementare
ZMS	Staubabscheider	Dust separator	Filtre séparateur	Separatore polveri
ZWS	Motorschutzschalter	Motor starter	Disjoncteur moteur	Interruttore magnetotermico
	Wechselschaltung	Change over valve	Inverseur de débit	Valvola di inversione

D 525

1.12.99

**Werner Rietschle
GmbH + Co. KG**

Postfach 1260

79642 SCHOPFHEIM
GERMANY

☎ 07622 / 392-0

Fax 07622 / 392300

E-Mail: info@rietschle.com

http://www.rietschle.com

SKP		253 20		302 20	358 26		
m³/h	50 Hz	125		175	280		
	60 Hz	135		200	320		
mbar (V)	50 Hz	160	180	220	120	210	275
	60 Hz	95	160	220	-	175	250
3~	50 Hz	230/400V ± 10%					
	60 Hz	220/380V					
1~	50 Hz	230V ± 10%			-		
	60 Hz	220V			-		
kW	50 Hz	0,55	0,75	1,5	1,5	2,2	3,0
	60 Hz	0,65	0,90	1,8	-	2,6	3,6
A (3~)	50 Hz	2,85/1,65	3,46/2,0	5,9/3,4	6,6/3,8	9,4/5,4	14,2/8,2
	60 Hz	3,46/2,0	4,5/2,6	7,4/4,3	-	11,0/6,4	15,9/9,2
A (1~)	50 Hz	4,5	5,8	-	-	-	-
	60 Hz	#	7,5	-	-	-	-
min⁻¹	50 Hz	2850					
	60 Hz	3450					
dB(A)	50 Hz	65			67	71	
	60 Hz	68			71	76	
kg	3~	20	22	33	43	45	48
	1~	23,5	24	-	-	-	-

m³/h	Volumenstrom	Capacity	Volume engendré	Portata volumetrica
mbar	Druckdifferenz	Pressure difference	Pression différentielle	Differenza di pressione
V	Vakuumbetrieb	Vacuum operation	Fonction dépression	Esercizio in aspirazione
3~/1~	Motorausführung	Motor version	Exécution moteur	Esecuzione motore
kW	Motorleistung	Motor rating	Puissance moteur	Potenza motore
A	Stromaufnahme	Current drawn	Intensité absorbée	Corrente nominale
min⁻¹	Drehzahl	Speed	Vitesse rotation	Numero giri
dB(A) → DIN 45635	Mittlerer Schalldruckpegel (Ausblasung über Schlauchleitung)	Average noise level (Discharge connected to a pipeline)	Niveau sonore moyen (Refoulement au travers d'un tuyau)	Rumorosità media (Scarico tramite tubazione flessibile)
kg	Max. Gewicht	Maximum weight	Poids maxi.	Peso massimo

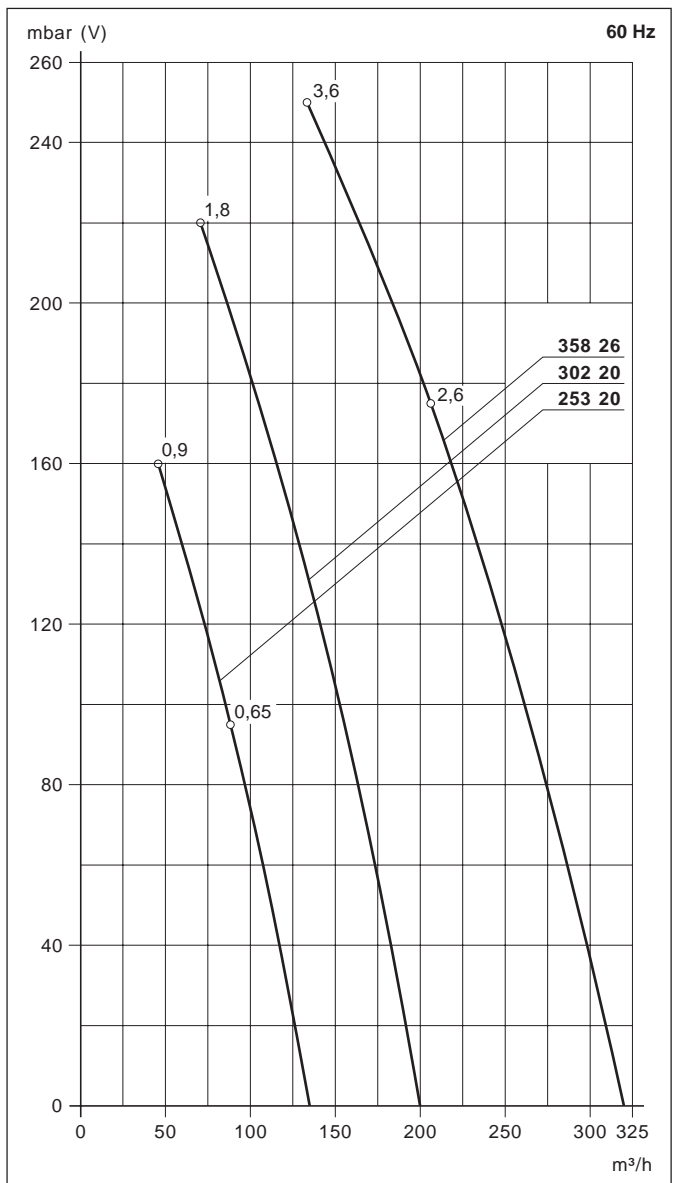
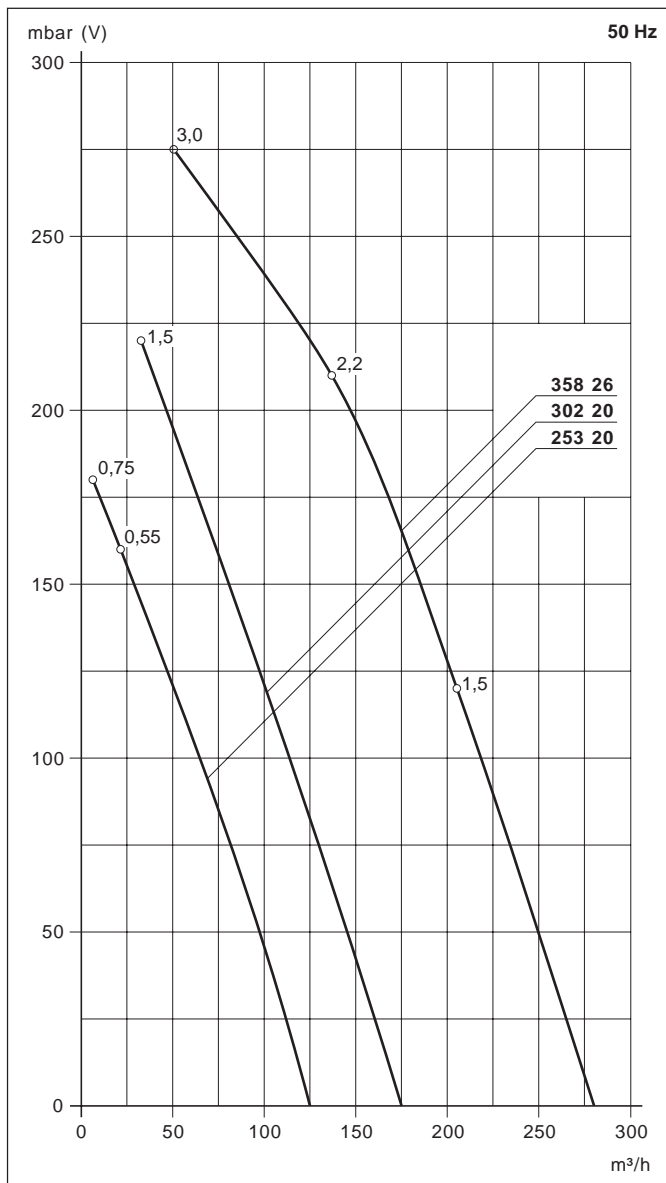

Die Kennlinien (Toleranz ±10%) gelten für den Zustand im Saugstutzen bei 20°C und einem Gegendruck von 1 bar (abs.)./ The curves have a tolerance of ±10% and are related to inlet conditions at 20°C and back pressure of 1 bar (abs.)./ Les courbes (tolérance ±10%) sont établies pour de l'air aspiré à 20°C et une pression au refoulement de 1 bar (abs.)./ Le curve caratteristiche (tolleranza ±10%) valgono per una temperatura di 20°C misurata alla bocca di aspirazione con una contropressione di 1 bar (ass.).

Technische Änderungen vorbehalten!// We reserve the right to alter technical information!// Sous réserve de modification technique!// Salvo modifiche tecniche!

auf Anfrage

on request

sur demande

a richiesta



SKP

Seitenkanal-Verdichter

Side channel compressors

Turbine latérale pression

Compressori a canali laterali



SKP 253 20

SKP 302 20

SKP 358 26

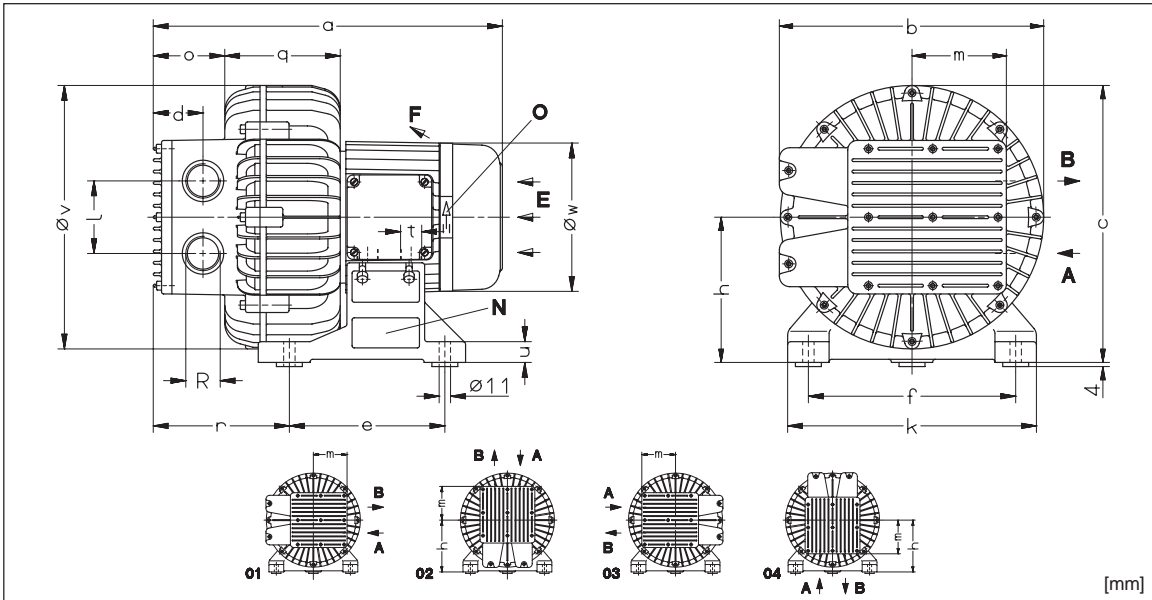

01-04	Anschlußstellungen	Connection positions	Positions raccordement	Posizioni di collegamenti
02	Normal-Ausführung	Standard version	Exécution standard	Esecuzione standard
A	Ansaug-Anschluß	Suction connection	Raccord d'aspiration	Attacco aspirazione
B	Druck-Anschluß	Pressure connection	Raccord surpression	Attacco pressione
E	Kühlluft-Eintritt	Cooling air entry	Entrée air refroidissement	Entrata aria di raffreddamento
F	Kühlluft-Austritt	Cooling air exit	Sortie air refroidissement	Uscita aria di raffreddamento
N	Datenschild	Data plate	Etiquette caractéristique	Targhetta dati
O	Drehrichtungsschild	Direction of rotation	Flèche sens rotation	Targhetta senso rotazione

SKP	253 20		302 20		358 26		
[mm]	a	3~ 375 1~ 375	394 416	429	480	503	511
	b	282		344	409		
	c	302		355	413		
	d / e	48 / 150		64 / 160	69 / 230		
	f / h	200 / 160		235 / 185	320 / 220		
	k / l	240 / 78		280 / 90	380 / 120		
	m	102		121	143		
	o	74		104	107		
	q	126		140	158		
	r	150		188	155		174
	t	M 20 x 1,5		M 25 x 1,5	M 25 x 1,5		M 32 x 1,5
	u	16		25	35		
	øv	284		340	385		
	øw	143		177	175		212
	R	G 1 1/4		G 2	G 2		

ZRK		32 (03)		50 (03)	50 (03)		
ZED/ZBD	50 Hz	ZED 32		ZBD 40	ZBD 65	ZBD 65	ZBD 40
	60 Hz	ZBD 40		ZBD 40	-	ZBD 65	ZBD 65
ZAF		32 (00)		50 (00)	50 (00)		
ZGD		32 (06)		50 (06)	50 (06)		
ZFP		216 (07)		216 (01)	216 (01)		
ZMS (3~)	50 Hz	40/24	60/24	100/40	100/40	100/60	160/100
	60 Hz	40/24	60/40	100/60	-	160/100	160/100
ZMS (1~)	50 Hz	60	100	-	-		
	60 Hz	#	100	-	-		
ZWS		61 (03)		83 (01)	83 (02)		

ZRK	Zubehör	Optional extras	Accessoires	Accessori
ZED/ZBD	Rückschlagventil	Non-return valve	Clapet anti-retour	Valvola di non ritorno
ZAF	Druck-Begrenzungsventil	Pressure limitation valve	Limiteur surpression	Valvola limitatrice di pressione
ZGD	Ansaugfilter	Suction filter	Filtre d'aspiration	Filtro di aspirazione
ZFP	Zusätzlicher Schalldämpfer	Additional silencer	Silencieux complémentaire	Silenziatore supplementare
ZMS	Staubabscheider	Dust separator	Filtre séparateur	Separatore polveri
ZWS	Motorschutzschalter	Motor starter	Disjoncteur moteur	Interruttore magnetotermico
	Wechselschaltung	Change over valve	Inverseur de débit	Valvola di inversione

D 625

1.11.99

Werner Rietschle GmbH + Co. KG

Postfach 1260

79642 SCHOPFHEIM
GERMANY

☎ 07622 / 3920

Fax 07622 / 392300

E-Mail: info@rietschle.com

http://www.rietschle.com

SKP		253 20		302 20	358 26		
m³/h	50 Hz	125		175	280		
	60 Hz	135		200	320		
mbar (P)	50 Hz	170	205	220	120	210	280
	60 Hz	105	160	220	-	160	250
3~	50 Hz	230/400V ± 10%					
	60 Hz	220/380V					
1~	50 Hz	230V ± 10%			-		
	60 Hz	220V			-		
kW	50 Hz	0,55	0,75	1,5	1,5	2,2	3,0
	60 Hz	0,65	0,90	1,8	-	2,6	3,6
A (3~)	50 Hz	2,85/1,65	3,46/2,0	5,9/3,4	6,6/3,8	9,4/5,4	14,2/8,2
	60 Hz	3,46/2,0	4,5/2,6	7,4/4,3	-	11,0/6,4	15,9/9,2
A (1~)	50 Hz	4,5	5,8				
	60 Hz	#	7,5				
min⁻¹	50 Hz	2850					
	60 Hz	3450					
dB(A)	50 Hz	65		67	71		
	60 Hz	68		71	76		
kg	3~	20	22	33	43	45	48
	1~	23,5	24				

m³/h	Volumenstrom	Capacity	Volume engendré	Portata volumetrica
mbar	Druckdifferenz	Pressure difference	Pression différentielle	Differenza di pressione
P	Druckbetrieb	Pressure operation	Fonction surpression	Pressione di esercizio
3~/1~	Motorausführung	Motor version	Exécution moteur	Esecuzione motore
kW	Motorleistung	Motor rating	Puissance moteur	Potenza motore
A	Stromaufnahme	Current drawn	Intensité absorbée	Corrente nominale
min⁻¹	Drehzahl	Speed	Vitesse rotation	Numero giri
dB(A) → DIN 45635	Mittlerer Schalldruckpegel (Ansaugung über Schlauchleitung)	Average noise level (Inlet connected to a pipeline)	Niveau sonore moyen (Aspiration au travers d'un tuyau)	Rumorosità media (Aspirazione tramite tubazione flessibile)
kg	Max. Gewicht	Maximum weight	Poids maxi.	Peso massimo

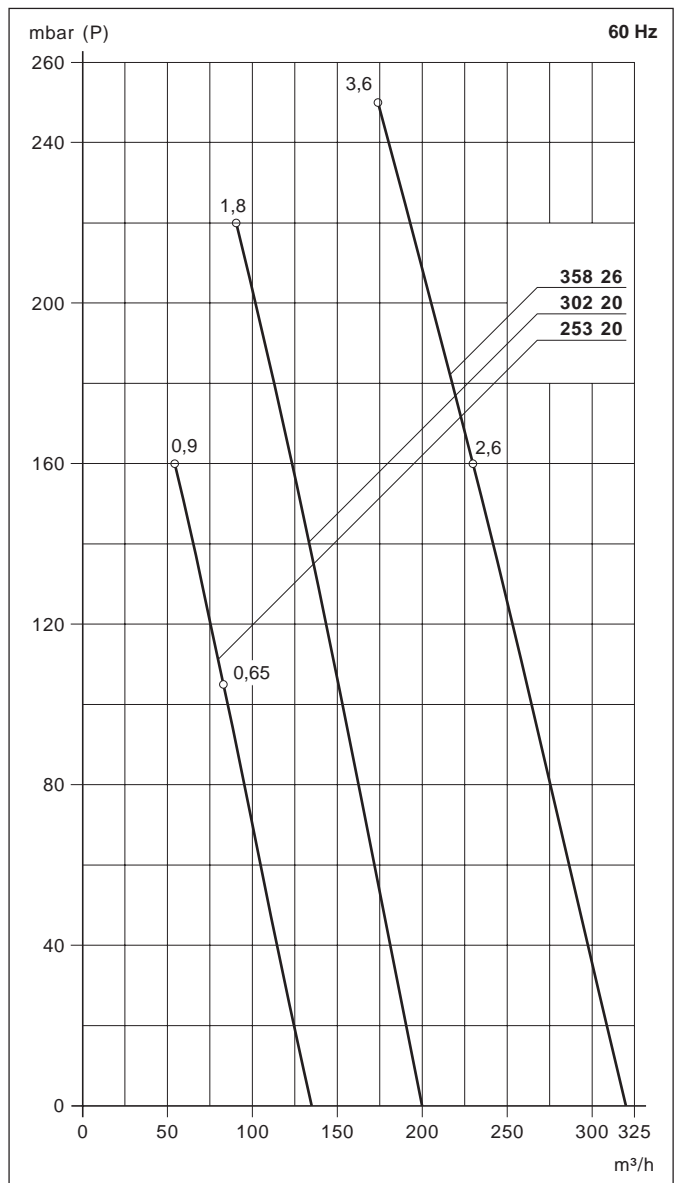
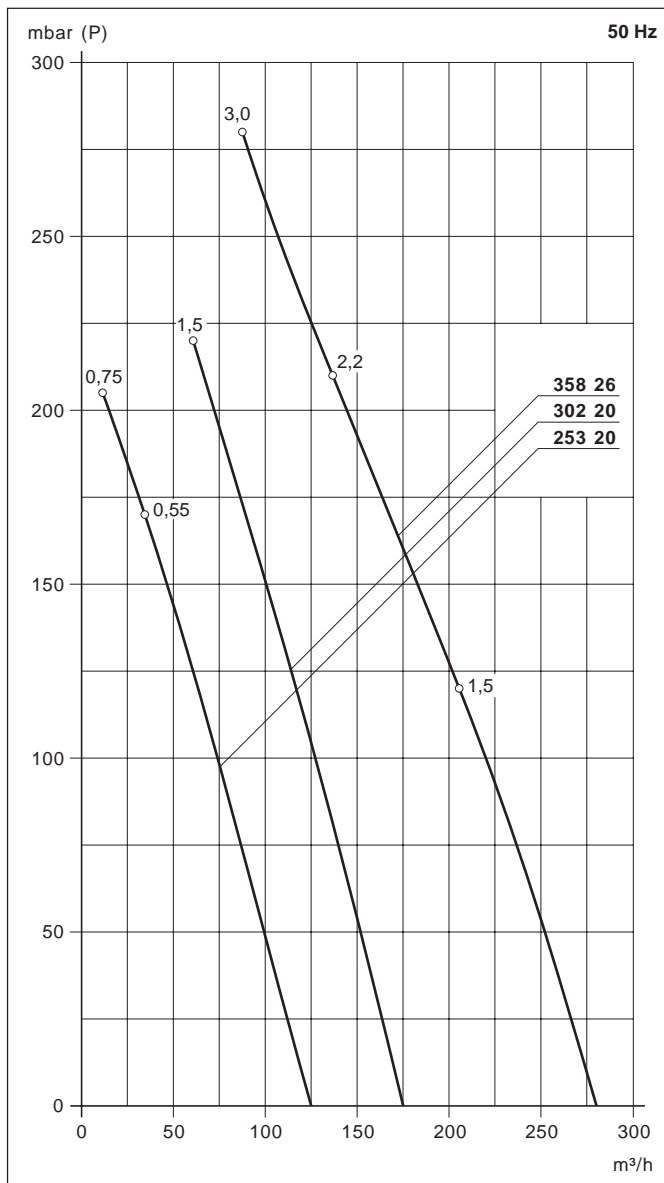

Die Kennlinien haben eine Toleranz von ± 10% und beziehen sich auf freie atmosphärische Luft von 1 bar (abs.) und 20°C./ The curves have a tolerance of ± 10% and refer to free atmospheric air at 1 bar (abs.) and 20°C./ Les courbes ont une tolérance de ± 10% et sont établies à l'atmosphère de 1 bar (abs.) à 20°C./ Le curve hanno una tolleranza del ± 10% e si riferiscono alla pressione atmosferica di 1 bar (ass.) e 20°C.

Technische Änderungen vorbehalten!// We reserve the right to alter technical information!// Sous réserve de modification technique!// Salvo modifiche tecniche!

auf Anfrage

on request

sur demande

a richiesta