

Wälzkolbengebläse  
Druckbetrieb

Rotary lobe blowers  
Pressure operation

Turbines piston rotatif  
Fonction surpression

Soffiatori lobo rotante  
Esercizio in pressione

WPB

**SHARK**

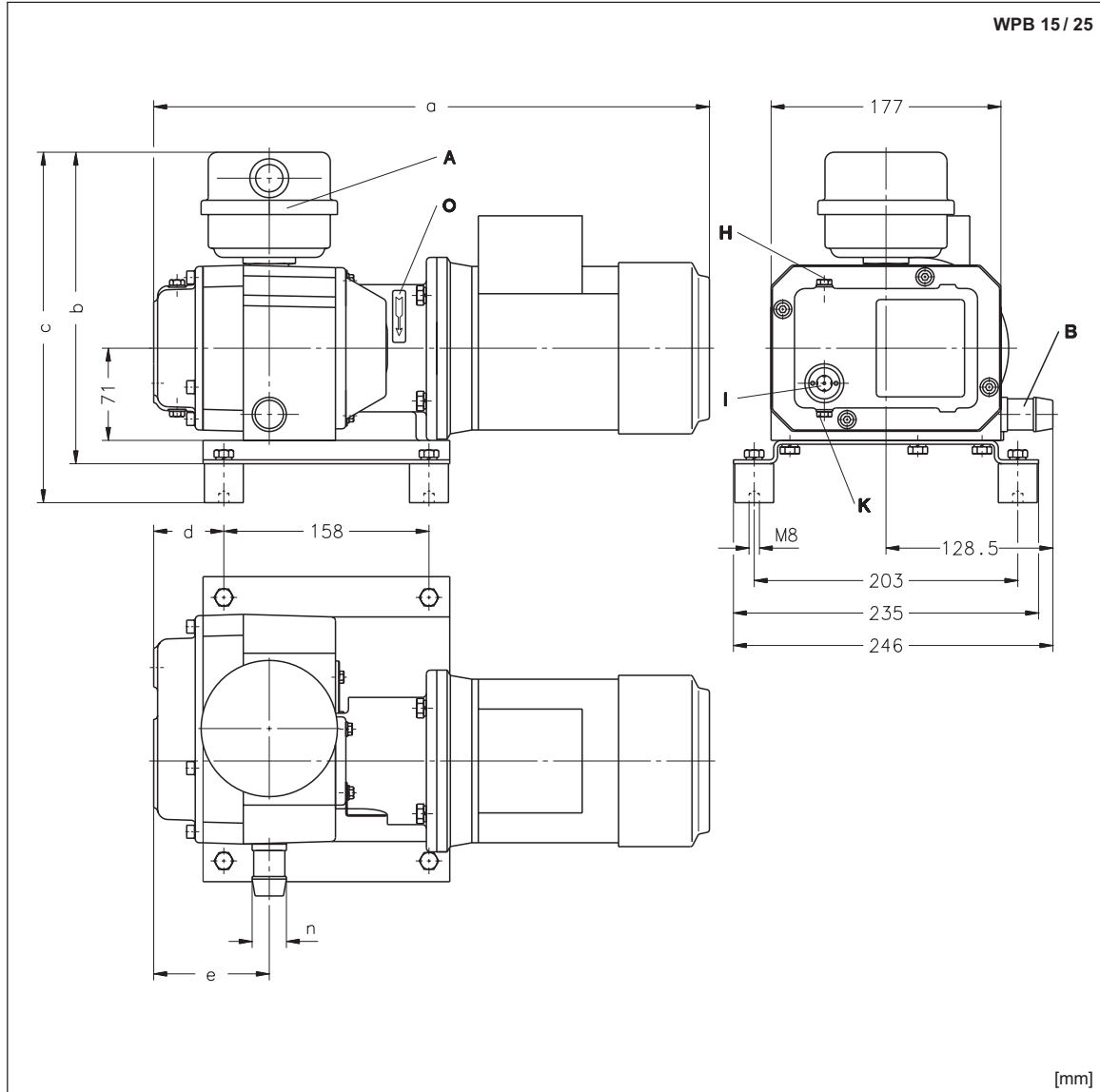

[mm]

- WPB 15
- WPB 25
- WPB 120
- WPB 300
- WPB 400
- WPB 430
- WPB 550
- WPB 750
- WPB 780
- WPB 1000
- WPB 1300
- WPB 1600
- WPB 2000
- WPB 3300
- WPB 5000
- WPB 6500
- WPB 8300

WPB 15 / 25	Kompaktgebläse	Compact blower	Turbine compacte	Soffiatore compatto
A	Ansaugung	Suction	Aspiration	Aspirazione
B	Druck-Anschluss	Pressure connection	Raccord surpression	Attacco pressione
H	Öleinfüllstelle	Oil filling point	Point de remplissage d'huile	Punto di riempimento olio
I	Ölkontrolle	Oil check	Contrôle d'huile	Spia controllo olio
K	Ölablassstelle	Oil drain point	Point de vidange d'huile	Punto scarico olio
O	Drehrichtungsschild	Direction of rotation	Flèche sens rotation	Targhetta senso rotazione

WPB		15	25
[mm]	a	412	428
	b	212	240
	c	242	270
	d	38	54
	e	83	89
	n	20	20

Frequenzregelung auf Anfrage./ Frequency control on request./ Régulation de fréquence sur demande./ Regolamentazione frequenza a richiesta.

D 862

2.3.2002

**Werner Rietschle GmbH + Co. KG**

Postfach 1260

D-79642 Schopfheim

☎ 07622/392-0

Fax 07622/392300

e-mail: info@rietschle.com

http://www.rietschle.com

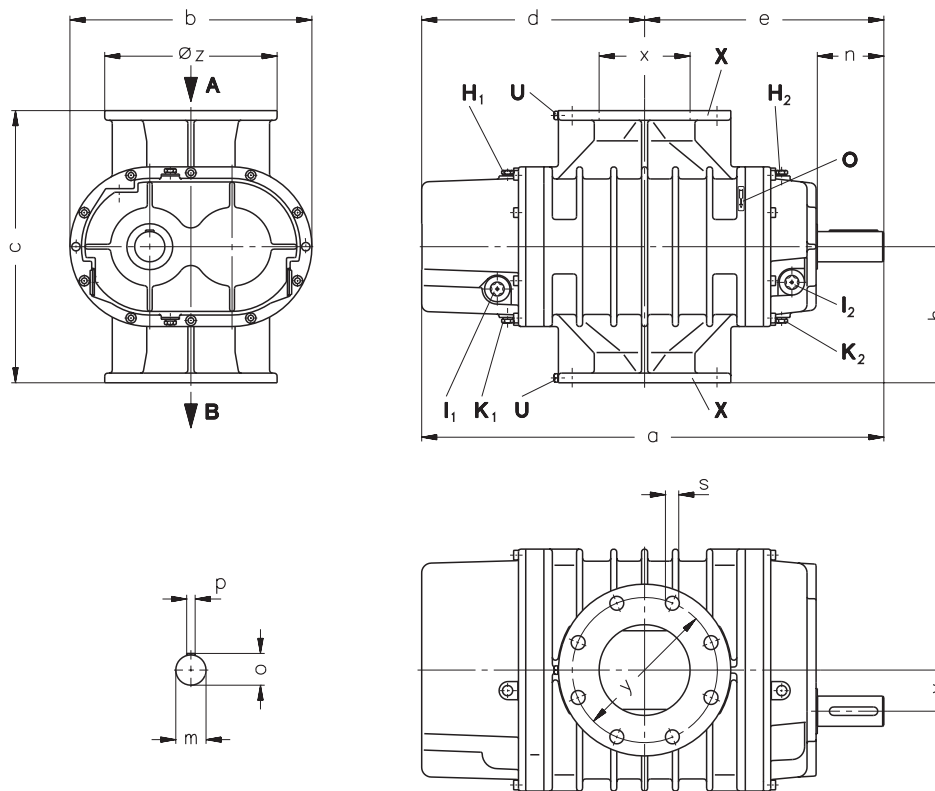

[mm]

<b>WPB (01)</b> A B H <sub>1</sub> , H <sub>2</sub> I <sub>1</sub> , I <sub>2</sub> K <sub>1</sub> , K <sub>2</sub> O U	<b>Grundeinheit</b> Ansaug-Anschluss Druck-Anschluss Öleinfüllstelle Ölkontrolle Ölablasstelle Drehrichtungsschild Messanschluss M 10 x 1	<b>Base unit</b> Suction connection Pressure connection Oil filling point Oil check Oil drain point Direction of rotation Gauge connection M 10 x 1	<b>Unité de base</b> Raccord d'aspiration Raccord surpression Point de remplissage d'huile Contrôle d'huile Point de vidange d'huile Flèche sens rotation Raccordement mesure M 10 x 1	<b>Unità base</b> Attacco aspirazione Attacco pressione Punto di riempimento olio Spia controllo olio Punto scarico olio Targhetta senso rotazione Attacco per la misurazione M 10x1
X	Flansch	Flange	Bride	Flangia
kg L <sub>1</sub> , L <sub>2</sub>	Gewicht Öleinfüllmenge	Weight Oil capacity	Poids Charge d'huile	Peso massimo Quantità olio

WPB (01)	120	300	400	430	550	750	780	1000	1300	1600	2000	3300	5000	6500	8300
a	309	380	415	464	464	515	593	593	651	714	767	858	1024	1102	1322
b	172	214	214	271	271	271	327	327	327	400	370	512	585	790	790
c	185	228	228	320	320	320	370	370	370	370	452	524	520	718	718
d	160	178	195,5	217	217	242,5	274	274	304	345	371,5	413	486	515	633
e	149	201,5	219,5	247	247	272,5	319	319	347	369	395,5	445	538	587	689
h	100	114	114	160	160	160	185	185	185	185	227	262	260	359	359
m	19	24	24	32	32	32	42	42	42	50	50	60	80	85	85
n	30	50	50	80	80	80	110	110	110	110	110	110	140	170	170
o	21,5	26,9	26,9	35,3	35,3	35,3	45,1	45,1	45,1	53,5	53,5	64,2	85	90,3	90,3
p	6	8	8	10	10	10	12	12	12	14	14	18	22	25	25
ø s	4 x 11	4 x 18	4 x 18	4 x 18	4 x 18	4 x 18	8 x 18	8 x 18	8 x 18	8 x 23	8 x 18	8 x 24	12 x M20	12 x 24	12 x 24
v	24,5	34	34	42,5	42,5	42,5	53,5	53,5	53,5	68	68	86	102,5	135	135
x	G 2,5 / 50	50	65	80	80	80	100	100	100	150	150	200	250	250	250
y	100	135	135	156	156	156	190	190	190	240	240	295	356	355	355
ø z	130	125x125	144x144	143x143	143x143	143x143	230	230	230	285	285	340	405	405	405
X	-	-	-	-	-	-	-	-	-	DN 150, PN 10	DN 150, PN 10	DN 200, PN 10	DN 250, PN 16	DN 250, PN 16	DN 250, PN 16
kg	19	40	43	73	73	82	118	118	133	211	252	396	640	905	1204
l → L <sub>1</sub> / L <sub>2</sub>	0,07 / 0,1	0,1 / 0,15	0,1 / 0,15	0,2 / 0,45	0,2 / 0,45	0,2 / 0,45	0,55 / 0,7	0,55 / 0,7	0,55 / 0,7	0,75 / 1,4	0,75 / 1,4	1,5 / 2,75	1,4 / 2,6	4,5 / 6,5	4,5 / 6,5

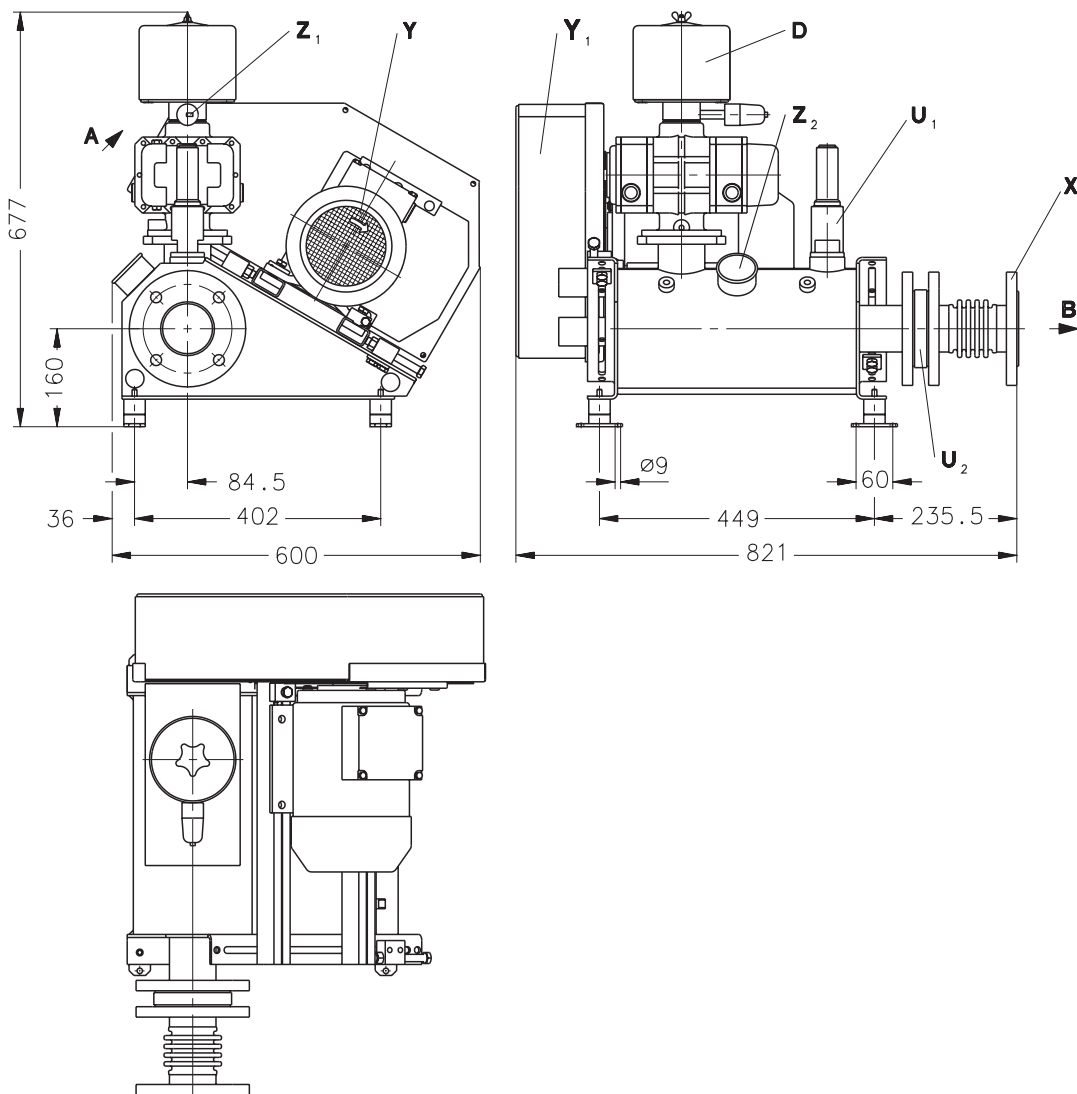

[mm]

WPB (30)	Kompakteinheit	Compact unit	Unité compacte	Gruppo elettrosoffiatore
A	Ansaugung	Suction	Aspiration	Aspirazione
B	Druck-Anschluss	Pressure connection	Raccord surpression	Attacco pressione
D	Saug-Schalldämpfer mit Filter	Inlet silencer with filter	Silencieux d'aspiration avec filtre	Silenziatore d'aspirazione con filtro
U <sub>1</sub>	Sicherheitsventil mit Anlaufentlastung	Safety valve with unloading valve	Clapet de sécurité avec décharge de démarrage	Valvola di sicurezza con avviamento a vuoto
U <sub>2</sub>	Rückschlagventil	Non-return valve	Clapet anti-retour	Valvola di non ritorno
X	Flansch DN 65 PN 10	Flange DN 65 PN 10	Bride DN 65 PN 10	Flangia DN 65 PN 10
Y	Antriebsmotor	Drive motor	Moteur d'entraînement	Motore di azionamento
Y <sub>1</sub>	Riemenantrieb	Belt drive	Courroie d'entraînement	Cinghie di trasmissione
Z <sub>1</sub>	Filterwartungsanzeige (Zubehör)	Filter servicing indicator (Optional extras)	Indicateur de maintenance de filtre (Accessoires)	Indicatore di manutenzione di filtro (Accessori)
Z <sub>2</sub>	Manometer	Manometer	Manomètre	Manometro
kg	Gewicht ohne Motor	Weight without motor	Poids sans moteur	Peso massimo senza motore

WPB (30)	120
kg	90

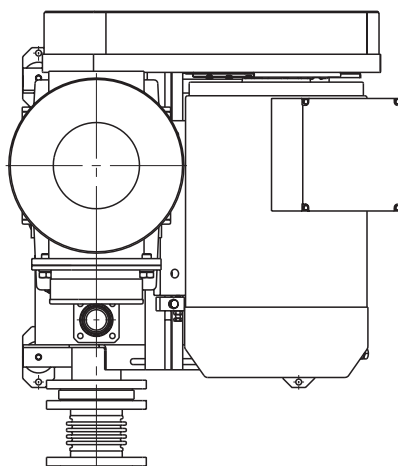
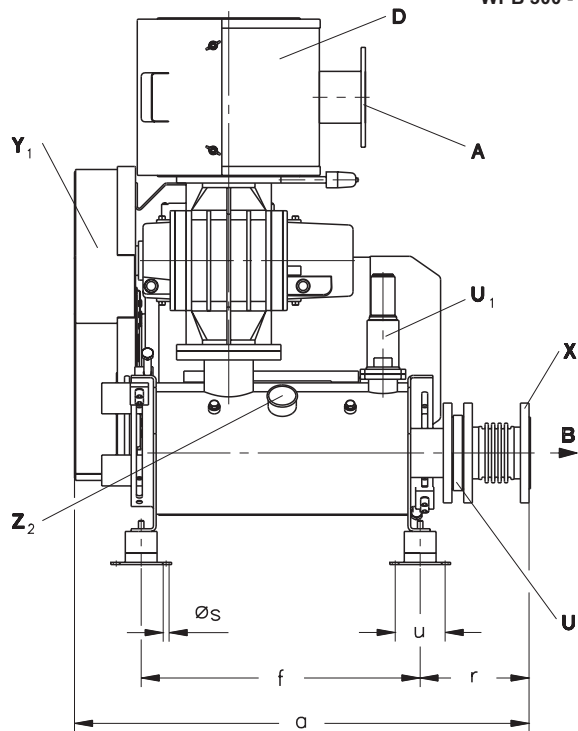
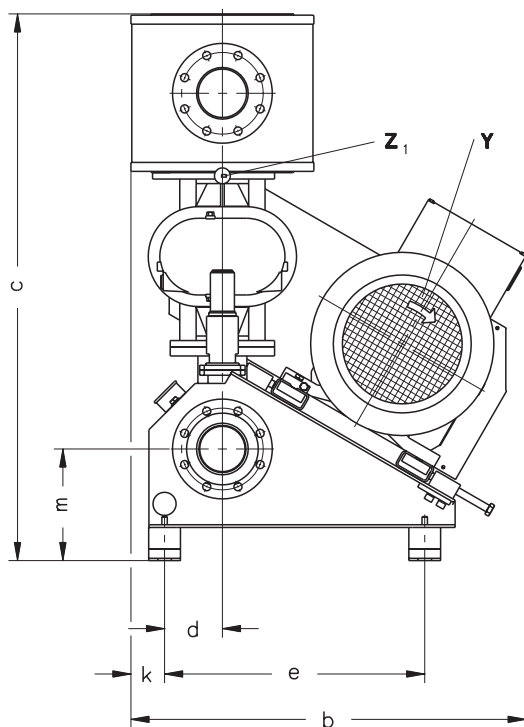

<b>WPB (30)</b>	<b>Kompakteinheit</b>	<b>Compact unit</b>	<b>Unité compacte</b>	<b>Gruppo elettrosoffiatore</b>
A	Ansaugung	Suction	Aspiration	Aspirazione
B	Druck-Anschluss	Pressure connection	Raccord surpression	Attacco pressione
D	Saug-Schalldämpfer mit Filter	Inlet silencer with filter	Silencieux d'aspiration avec filtre	Silenziatore d'aspirazione con filtro
U <sub>1</sub>	Sicherheitsventil mit Anlaufentlastung	Safety valve with unloading valve	Clapet de sécurité avec décharge de démarrage	Valvola di sicurezza con avviamento a vuoto
U <sub>2</sub>	Rückschlagventil	Non-return valve	Clapet anti-retour	Valvola di non ritorno
X	Flansch	Flange	Bride	Flangia
Y	Antriebsmotor	Drive motor	Moteur d'entraînement	Motore di azionamento
Y <sub>1</sub>	Riemenantrieb	Belt drive	Courroie d'entraînement	Cinghie di trasmissione
Z <sub>1</sub>	Filterwartungsanzeige	Filter servicing indicator	Indicateur de maintenance de filtre	Indicatore di manutenzione di filtro
Z <sub>2</sub>	Manometer	Manometer	Manomètre	Manometro
kg	Gewicht ohne Motor	Weight without motor	Poids sans moteur	Peso massimo senza motore

WPB (30)		300	400	430	550	750	780	1000	
[mm]	a	843	855	881	974	1000	1005	1009	
	b	600		749	754		871		
	c	777		991	1098	1088	1152	1205	
	d			84,5			85	128	
	e			402			508	574	
	f			449			621		
	k	36			115			117	74
	m			160			246		
	r			235,5	231	233	234	237	
	Øs			9			13		
u			60			110			
X			DN 65 PN 10		DN 80 PN 10		DN 100 PN 10		
kg		105	110	140	230	230	270	306	

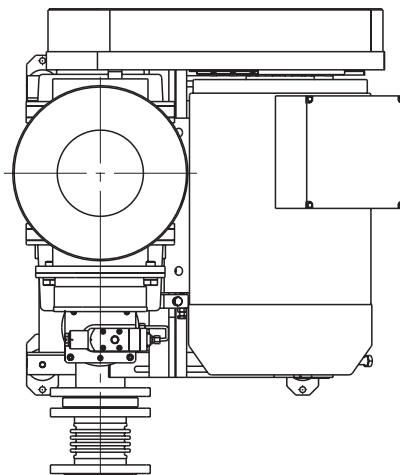
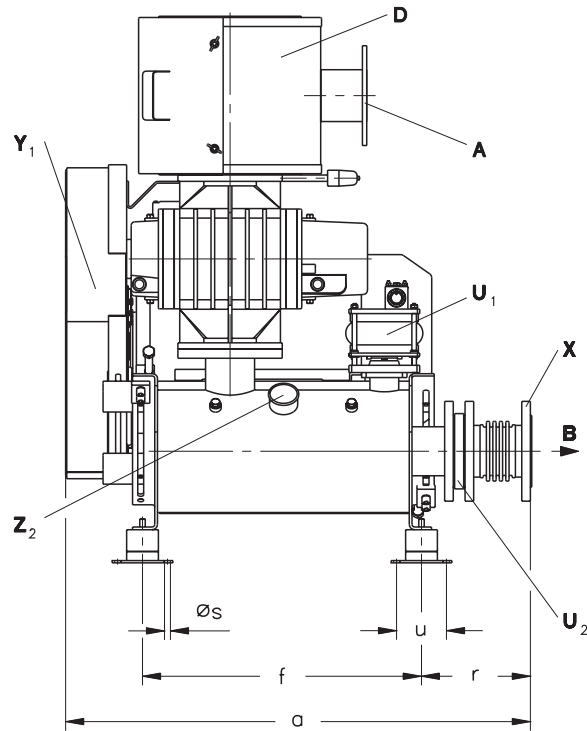
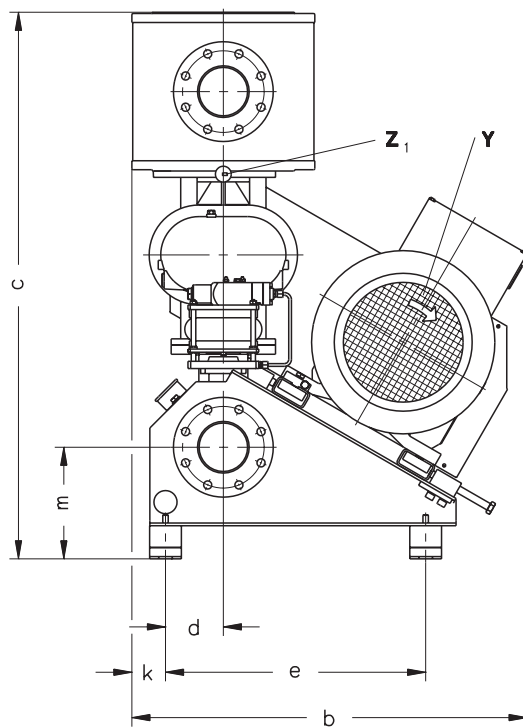

<b>WPB (30)</b>	<b>Kompakteinheit</b>	<b>Compact unit</b>	<b>Unité compacte</b>	<b>Gruppo elettrosoffiatore</b>
A	Ansaugung	Suction	Aspiration	Aspirazione
B	Druck-Anschluss	Pressure connection	Raccord surpression	Attacco pressione
D	Saug-Schalldämpfer mit Filter	Inlet silencer with filter	Silencieux d'aspiration avec filtre	Silenziatore d'aspirazione con filtro
U <sub>1</sub>	Sicherheitsventil mit Anlaufentlastung	Safety valve with unloading valve	Clapet de sécurité avec décharge de démarrage	Valvola di sicurezza con avviamento a vuoto
U <sub>2</sub>	Rückschlagventil	Non-return valve	Clapet anti-retour	Valvola di non ritorno
X	Flansch DN 65 PN 10	Flange DN 65 PN 10	Bride DN 65 PN 10	Flangia DN 65 PN 10
Y	Antriebsmotor	Drive motor	Moteur d'entraînement	Motore di azionamento
Y <sub>1</sub>	Riemenantrieb	Belt drive	Courroie d'entraînement	Cinghie di trasmissione
Z <sub>1</sub>	Filterwartungsanzeige	Filter servicing indicator	Indicateur de maintenance de filtre	Indicatore di manutenzione di filtro
Z <sub>2</sub>	Manometer	Manometer	Manomètre	Manometro
kg	Gewicht ohne Motor	Weight without motor	Poids sans moteur	Peso massimo senza motore

WPB (30)		1300	1600
[mm]	a	1038	1073
	b	871	868
	c	1205	1226
	d	128	128
	e	574	574
	f	621	621
	k	74	74
	m	246	246
	r	237	245
	Øs	13	13
u	110	110	
X	DN 100 PN 10	DN 150 PN 10	
kg		320	360

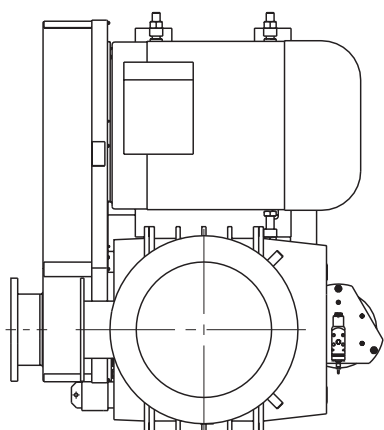
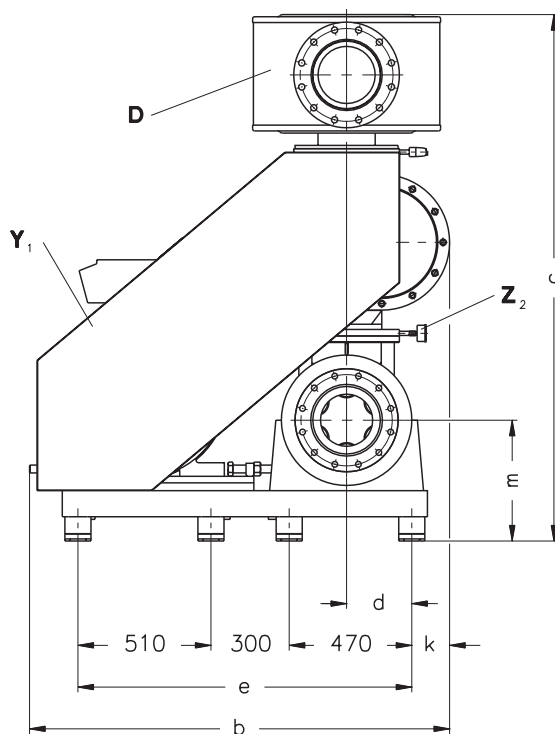
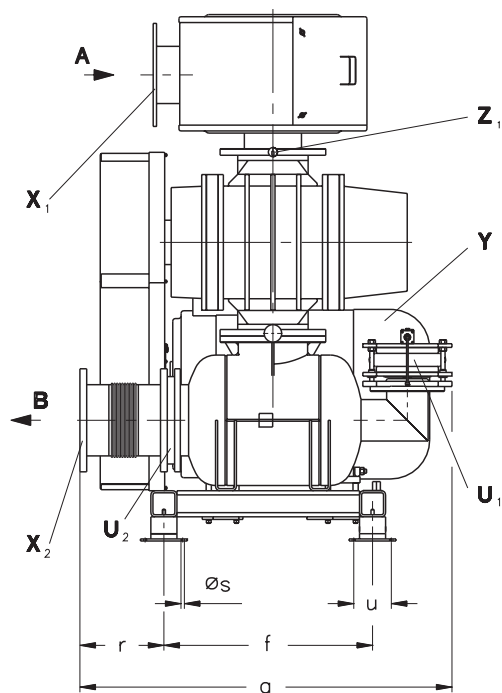

WPB 2000/3300 (30)

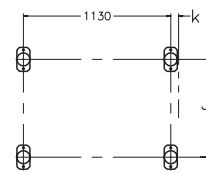

WPB 8300 (30)

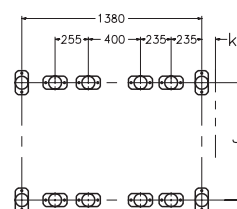

[mm]

WPB (30)	Kompakteinheit	Compact unit	Unité compacte	Gruppo elettrosfiatore
A	Ansaugung	Suction	Aspiration	Aspirazione
B	Druck-Anschluss	Pressure connection	Raccord surpression	Attacco pressione
D	Saug-Schalldämpfer mit Filter	Inlet silencer with filter	Silencieux d'aspiration avec filtre	Silenziatore d'aspirazione con filtro
U <sub>1</sub>	Sicherheitsventil mit Anlaufentlastung	Safety valve with unloading valve	Clapet de sécurité avec décharge de démarrage	Valvola di sicurezza con avviamento a vuoto
U <sub>2</sub>	Rückschlagventil	Non-return valve	Clapet anti-retour	Valvola di non ritorno
X	Flansch	Flange	Bride	Flangia
Y	Antriebsmotor	Drive motor	Moteur d'entraînement	Motore di azionamento
Y <sub>1</sub>	Riemenantrieb	Belt drive	Courroie d'entraînement	Cinghie di trasmissione
Z <sub>1</sub>	Filterwartungsanzeige	Filter servicing indicator	Indicateur de maintenance de filtre	Indicatore di manutenzione di filtro
Z <sub>2</sub>	Manometer	Manometer	Manomètre	Manometro
kg	Gewicht ohne Motor	Weight without motor	Poids sans moteur	Peso massimo senza motore

WPB (30)		2000	3300	5000	6500	8300
[mm]	a	1280		1426		1704,5
	b	1350	1409	1575	1611	1670,5
	c	1531	1682	1820	2018	2023
	d	215		250	250	300
	e	1130		1280	1280	1380
	f	750		800	800	900
	k	60	112	110	145	105
	m	433	413	463		
	r	311		322		339
	Øs	13		13		
u	144		144			
X <sub>1</sub>	DN 150 PN 10	DN 200 PN 10		DN 250 PN 16		
X <sub>2</sub>	DN 200 PN 10		DN 250 PN 10		DN 300 PN 10	
kg	729	835	1277	1528	1879	

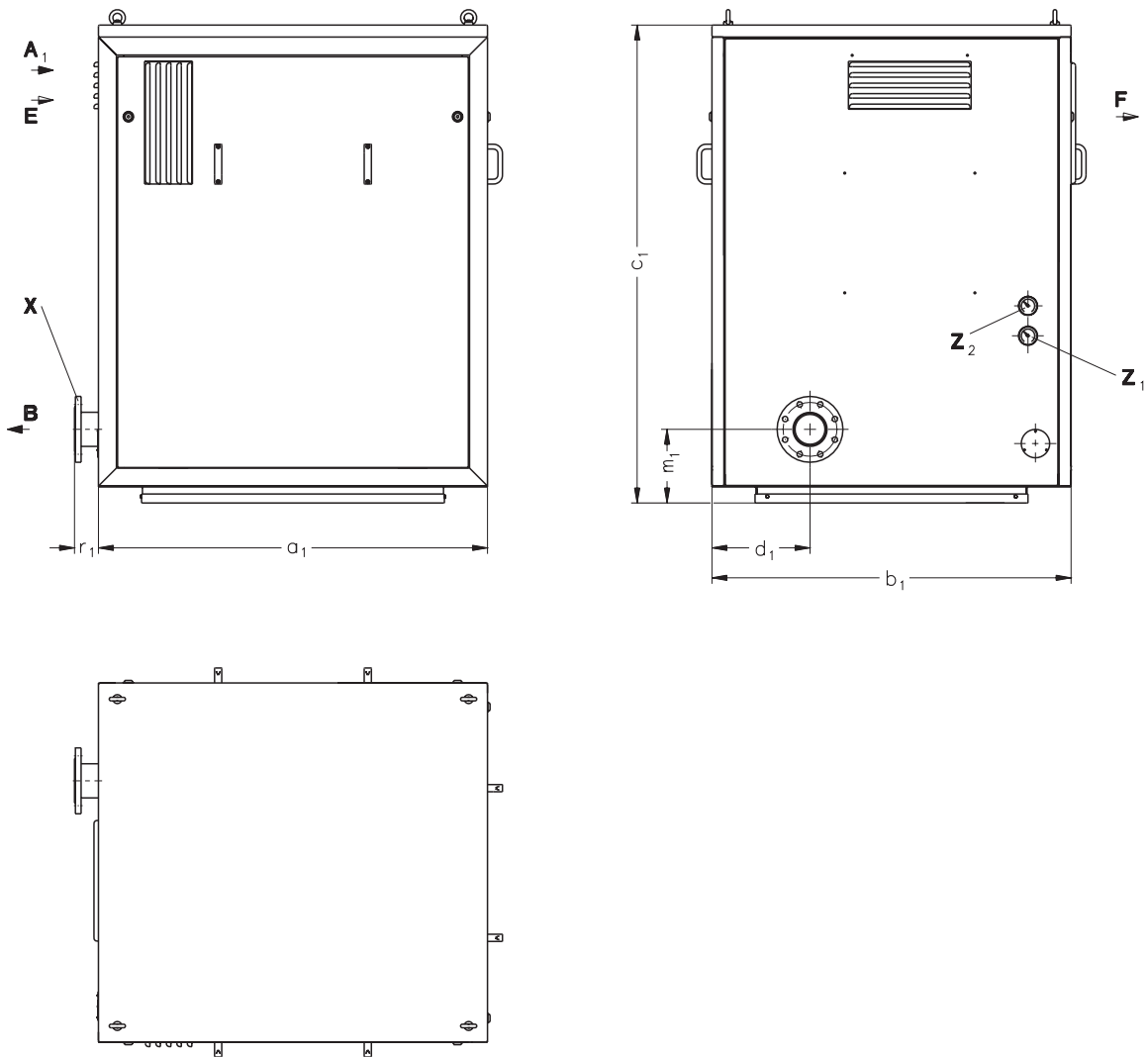

<b>WPB (60)</b>	<b>Kompakteinheit mit Schallbox</b>	<b>Compact unit with acoustic enclosure</b>	<b>Unité compacte avec caisson insonorisant</b>	<b>Gruppo elettrosfiatore con box insonorizzante</b>
A <sub>1</sub>	Ansaugung	Suction	Aspiration	Aspirazione
B	Druck-Anschluss	Pressure connection	Raccord surpression	Attacco pressione
E	Kühlluft-Eintritt	Cooling air entry	Entrée air refroidissement	Entrata aria di raffreddamento
F	Kühlluft-Austritt	Cooling air exit	Sortie air refroidissement	Uscita aria di raffreddamento
X	Flansch	Flange	Bride	Flangia
Z <sub>1</sub>	Filterwartungsanzeige	Filter servicing indicator	Indicateur de maintenance de filtre	Indicatore di manutenzione di filtro
Z <sub>2</sub>	Manometer	Manometer	Manomètre	Manometro
kg	Gewicht ohne Motor	Weight without motor	Poids sans moteur	Peso massimo senza motore

WPB (60)		120	300	400	430	550	750	780	1000	1300	1600	
[mm]	a <sub>1</sub>	1065				1150			1300			
	b <sub>1</sub>	920				950			1200			
	c <sub>1</sub>	1210				1346,5			1596,5			
	d <sub>1</sub>	235				255			327			
	m <sub>1</sub>	160				246			246			
	r <sub>1</sub>	100				100			80			
X	DN 65 PN 16					DN 80 PN 10			DN 100 PN 10		DN 150 PN 10	
kg	265	280	285	315	430	430	470	591	605	645		

WPB 2000 - 6500 (60)

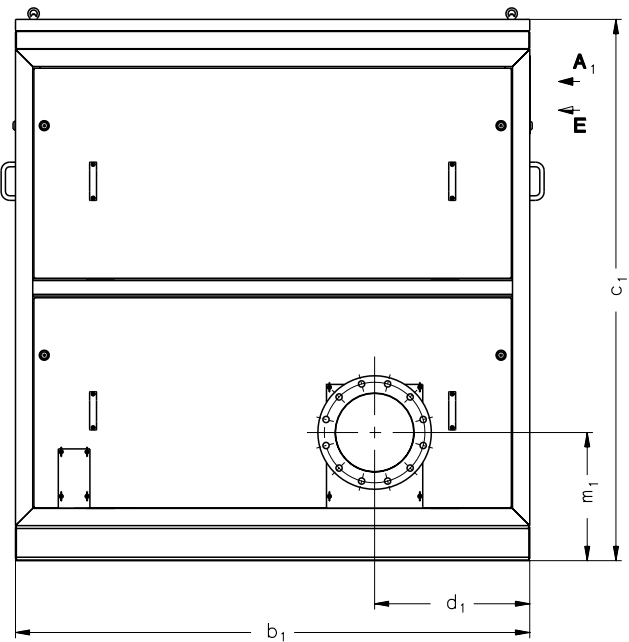
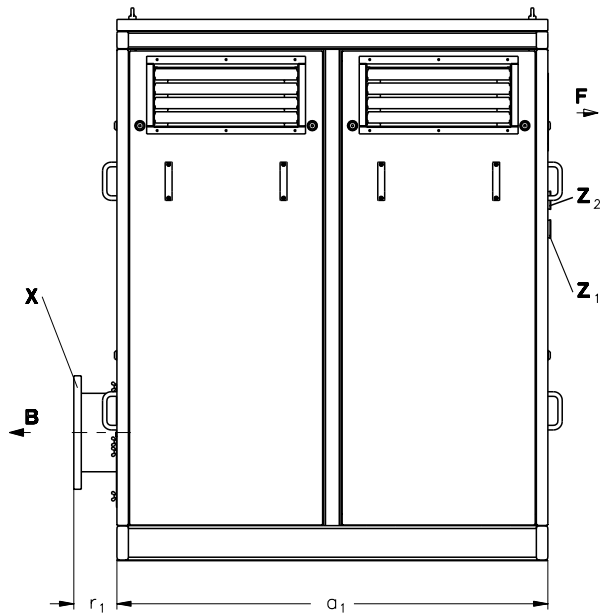

WPB 8300 (60)

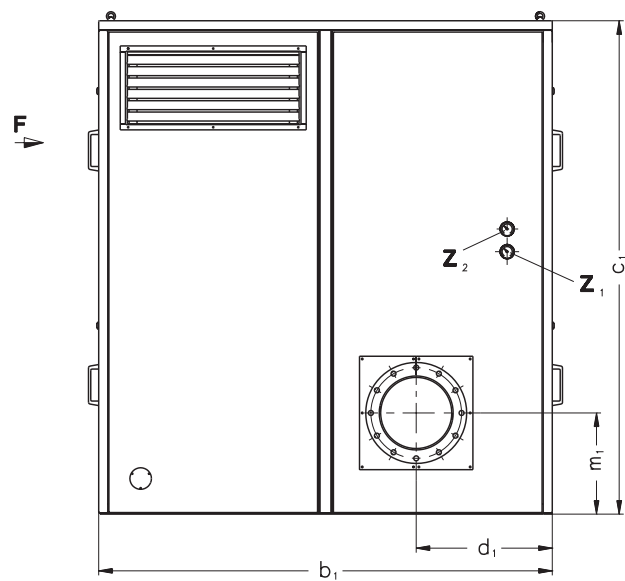
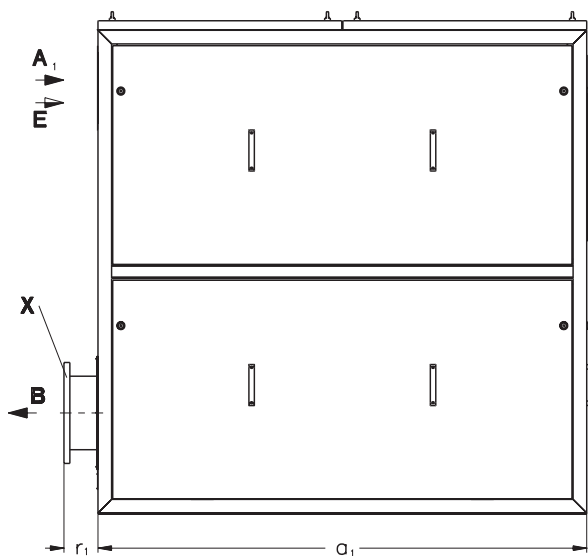

WPB (60)	Kompakteinheit mit Schallbox	Compact unit with acoustic enclosure	Unité compacte avec caisson insonorisant	Gruppo elettrosoffiatore con box insonorizzante
A <sub>1</sub>	Ansaugung	Suction	Aspiration	Aspirazione
B	Druck-Anschluss	Pressure connection	Raccord surpression	Attacco pressione
E	Kühlluft-Eintritt	Cooling air entry	Entrée air refroidissement	Entrata aria di raffreddamento
F	Kühlluft-Austritt	Cooling air exit	Sortie air refroidissement	Uscita aria di raffreddamento
X	Flansch	Flange	Bride	Flangia
Z <sub>1</sub>	Filterwartungsanzeige	Filter servicing indicator	Indicateur de maintenance de filtre	Indicatore di manutenzione di filtro
Z <sub>2</sub>	Manometer	Manometer	Manomètre	Manometro
kg	Gewicht ohne Motor	Weight without motor	Poids sans moteur	Peso massimo senza motore

WPB (60)		2000	3300	5000	6500	8300
[mm]	a <sub>1</sub>	1500				2155
	b <sub>1</sub>	1790				2000
	c <sub>1</sub>	1822		2075		2175
	d <sub>1</sub>	540				600
	m <sub>1</sub>	413	433	463		463
	r <sub>1</sub>	100		150		150
	X	DN 200 PN 10		DN 250 PN 10		DN 300 PN 10
	kg	1229	1335	1827	2078	2489



WPB 15															
Δ p = 70 mbar							Δ p = 140 mbar								
m³/h	Δ t (°C)	kW (erf)	kW (M)	min⁻¹		IEC (M)	dB(A)	m³/h	Δ t (°C)	kW (erf)	kW (M)	min⁻¹		IEC (M)	dB(A)
				G	M							G	M		
14,8	7	0,1	0,37	2740	2740	71	72	13,3	16	0,1	0,37	2740	2740	71	73

WPB 15															
Δ p = 210 mbar							Δ p = 280 mbar								
m³/h	Δ t (°C)	kW (erf)	kW (M)	min⁻¹		IEC (M)	dB(A)	m³/h	Δ t (°C)	kW (erf)	kW (M)	min⁻¹		IEC (M)	dB(A)
				G	M							G	M		
12,2	27	0,1	0,37	2740	2740	71	74	11,2	39	0,1	0,37	2740	2740	71	75

WPB 15															
Δ p = 350 mbar							Δ p = 420 mbar								
m³/h	Δ t (°C)	kW (erf)	kW (M)	min⁻¹		IEC (M)	dB(A)	m³/h	Δ t (°C)	kW (erf)	kW (M)	min⁻¹		IEC (M)	dB(A)
				G	M							G	M		
10,2	53	0,1	0,37	2740	2740	71	77	9,3	69	0,2	0,37	2740	2740	71	78

WPB 15															
Δ p = 490 mbar							Δ p = 560 mbar								
m³/h	Δ t (°C)	kW (erf)	kW (M)	min⁻¹		IEC (M)	dB(A)	m³/h	Δ t (°C)	kW (erf)	kW (M)	min⁻¹		IEC (M)	dB(A)
				G	M							G	M		
8,4	89	0,2	0,37	2740	2740	71	78	7,5	115	0,3	0,37	2740	2740	71	79

WPB 25															
Δ p = 70 mbar							Δ p = 140 mbar								
m³/h	Δ t (°C)	kW (erf)	kW (M)	min⁻¹		IEC (M)	dB(A)	m³/h	Δ t (°C)	kW (erf)	kW (M)	min⁻¹		IEC (M)	dB(A)
				G	M							G	M		
26,1	7	0,1	0,55	2800	2800	71	73	24,2	15	0,1	0,55	2800	2800	71	75

WPB 25															
Δ p = 210 mbar							Δ p = 280 mbar								
m³/h	Δ t (°C)	kW (erf)	kW (M)	min⁻¹		IEC (M)	dB(A)	m³/h	Δ t (°C)	kW (erf)	kW (M)	min⁻¹		IEC (M)	dB(A)
				G	M							G	M		
22,7	24	0,1	0,55	2800	2800	71	75	21,4	34	0,2	0,55	2800	2800	71	76

WPB 25															
Δ p = 350 mbar							Δ p = 420 mbar								
m³/h	Δ t (°C)	kW (erf)	kW (M)	min⁻¹		IEC (M)	dB(A)	m³/h	Δ t (°C)	kW (erf)	kW (M)	min⁻¹		IEC (M)	dB(A)
				G	M							G	M		
20,3	45	0,3	0,55	2800	2800	71	78	19,3	57	0,3	0,55	2800	2800	71	79

WPB 25															
Δ p = 490 mbar							Δ p = 560 mbar								
m³/h	Δ t (°C)	kW (erf)	kW (M)	min⁻¹		IEC (M)	dB(A)	m³/h	Δ t (°C)	kW (erf)	kW (M)	min⁻¹		IEC (M)	dB(A)
				G	M							G	M		
18,3	70	0,4	0,55	2800	2800	71	80	17,4	84	0,5	0,55	2800	2800	71	81

Δ p (mbar)	Druckdifferenz	Pressure difference	Pression différentielle	Differenza di pressione
min⁻¹	Drehzahl	Speed	Vitesse rotation	Numero giri
G / M	Gebälse / Motor	Blower / Motor	Turbine / Moteur	Soffiante / Motore
Δ t (°C)	Temperaturdifferenz	Temperature difference	Différence de température	Differenza di temperatura
kW (erf)	erforderliche Leistung	Capacity required	Puissance néssaire	Potenza necessaria
kW (M)	Motorleistung	Motor rating	Puissance moteur	Potenza motore
IEC (M)	IEC Motor-Baugröße	IEC Motor size	Série IEC de moteur	Grandezza IEC del motore
dB(A) → DIN 45635	Mittlerer Schalldruckpegel	Average noise level	Niveau sonore moyen	Rumorosità media

WPB 120															
Δ p = 200 mbar								Δ p = 300 mbar							
m³/h	Δ t (°C)	kW (erf)	kW (M)	min <sup>-1</sup>		IEC (M)	dB(A) (60) / (30)	m³/h	Δ t (°C)	kW (erf)	kW (M)	min <sup>-1</sup>		IEC (M)	dB(A) (60) / (30)
				G	M							G	M		
23	25	0,21	0,37	1448	1370	71-4s	67 / 77	21	41	0,32	0,55	1473	1395	80-4	68 / 78
27	24	0,235	0,37	1616	1370	71-4s	69 / 79	26	38	0,356	0,55	1645	1395	80-4	71 / 81
38	22	0,3	0,37	2046	2740	71-2	70 / 81	35	35	0,44	0,55	2045	2800	71-2	73 / 83
49	20	0,37	0,55	2503	2800	71-2	73 / 84	45	32	0,53	0,75	2422	2855	80-2	75 / 85
60	20	0,43	0,55	2958	2800	71-2	76 / 86	55	31	0,62	0,75	2855	2855	80-2	77 / 87
65	19	0,47	0,75	3178	2855	80-2	76 / 86	63	30	0,69	1,1	3167	2845	80-2	77 / 87
74	19	0,52	0,75	3555	2855	80-2	77 / 87	72	29	0,7	1,1	3542	2845	80-2	77 / 86
81	19	0,56	0,75	3824	2855	80-2	77 / 88	79	29	0,83	1,1	3810	2845	80-2	77 / 87
93	18	0,63	1,1	4294	2845	80-2	77 / 88	91	28	0,94	1,5	4317	2860	90S-2	78 / 88
106	18	0,71	1,1	4837	2845	80-2	78 / 90	104	28	1,06	1,5	4856	2860	90S-2	79 / 91

WPB 120															
Δ p = 400 mbar								Δ p = 500 mbar							
m³/h	Δ t (°C)	kW (erf)	kW (M)	min <sup>-1</sup>		IEC (M)	dB(A) (60) / (30)	m³/h	Δ t (°C)	kW (erf)	kW (M)	min <sup>-1</sup>		IEC (M)	dB(A) (60) / (30)
				G	M							G	M		
20	60	0,42	0,55	1473	1395	80-4	69 / 79	19	79	0,53	0,75	1473	1395	80-4	70 / 80
24	55	0,47	0,75	1645	1395	80-4	72 / 82	23	72	0,59	0,75	1645	1395	80-4	73 / 83
33	49	0,58	0,75	3824	2855	80-2	74 / 84	34	61	0,76	1,1	2124	2845	80-2	75 / 85
43	45	0,7	1,1	2414	2845	80-2	76 / 86	42	58	0,87	1,1	2414	2845	80-2	77 / 87
53	42	0,82	1,1	2845	2845	80-2	78 / 88	52	54	1,03	1,5	2860	2860	90S-2	78 / 88
62	41	0,92	1,5	3183	2860	90S-2	78 / 88	60	52	1,14	1,5	3183	2860	90S-2	78 / 89
71	40	1,03	1,5	3561	2860	90S-2	79 / 89	70	51	1,3	2,2	3586	2880	90L-2	80 / 90
77	43	1,1	1,5	3830	2860	90S-2	79 / 90	77	50	1,4	2,2	3857	2880	90L-2	80 / 91
90	38	1,25	2,2	4347	2880	90L-2	80 / 91	89	49	1,56	2,2	4347	2880	90L-2	81 / 92
103	38	1,41	2,2	4890	2880	90L-2	81 / 93	102	48	1,76	2,2	4891	2880	90L-2	82 / 94

WPB 120															
Δ p = 600 mbar								Δ p = 700 mbar							
m³/h	Δ t (°C)	kW (erf)	kW (M)	min <sup>-1</sup>		IEC (M)	dB(A) (60) / (30)	m³/h	Δ t (°C)	kW (erf)	kW (M)	min <sup>-1</sup>		IEC (M)	dB(A) (60) / (30)
				G	M							G	M		
18	97	0,64	1,1	1495	1415	90S-4	72 / 82	22	105	0,84	1,1	1669	1415	90S-4	74 / 84
23	88	0,72	1,1	1669	1415	90S-4	74 / 84	31	92	1,01	1,5	2021	2860	90S-2	77 / 87
34	75	0,92	1,5	2135	2860	90S-2	77 / 87	40	84	1,22	1,5	2427	2860	90S-2	78 / 88
41	71	1,05	1,5	2427	2860	90S-2	78 / 88	51	78	1,45	2,2	2880	2880	90L-2	80 / 90
52	66	1,23	1,5	2860	2860	90S-2	79 / 89	59	75	1,6	2,2	3206	2880	90L-2	81 / 91
60	64	1,38	2,2	3206	2880	90L-2	80 / 90	69	73	1,8	2,2	3586	2880	90L-2	82 / 92
69	62	1,54	2,2	3586	2880	90L-2	81 / 91	75	71	1,92	3	3871	2890	100L-2	82 / 93
76	61	1,66	2,2	3857	2880	90L-2	81 / 92	87	69	2,2	3	4362	2890	100L-2	83 / 94
88	59	1,9	3	4362	2890	100L-2	82 / 93	101	68	2,5	3	4908	2890	100L-2	83 / 95
102	58	2,2	3	4908	2890	100L-2	83 / 95								

m³/h	Volumenstrom	Capacity	Volume engendré	Portata volumetrica
------	--------------	----------	-----------------	---------------------

Der Volumenstrom bezieht sich auf freie atmosphärische Luft von 1 bar (abs.) und 20° C./ The capacity refers to free atmospheric air at 1 bar (abs.) and 20° C./  
 Le débit est mesuré à l'atmosphère de 1 bar (abs.) à 20° C./ La portata si riferisce alla pressione atmosferica di 1 bar (ass.) e 20° C.  
 Tabellenangaben beziehen sich auf betriebswarme Verdichter./ Tables refer to compressor at normal operating temperature./ Les tableaux sont établies, compresseur à température de fonctionnement./ I dati riportati nelle tabelle si riferiscono ai compressori con funzionamento a regime.  
 Technische Änderungen vorbehalten! / We reserve the right to alter technical information! / Sous réserve de modification technique! / Salvo modifiche tecniche!

WPB 300															
Δ p = 300 mbar								Δ p = 400 mbar							
m³/h	Δ t (°C)	kW (erf)	kW (M)	min <sup>-1</sup>		IEC (M)	dB(A) (60) / (30)	m³/h	Δ t (°C)	kW (erf)	kW (M)	min <sup>-1</sup>		IEC (M)	dB(A) (60) / (30)
				G	M							G	M		
83	35	1,05	1,5	2021	2860	90S-2	61/78	79	50	1,4	2,2	2035	2880	90L-2	61/78
99	33	1,2	1,5	2296	2860	90S-2	62/78	95	47	1,6	2,2	2312	2880	90L-2	63/80
122	32	1,4	2,2	2688	2880	90L-2	64/79	118	44	1,9	3	2697	2890	100L-2	65/81
133	31	1,5	2,2	2880	2880	90L-2	65/80	129	44	2	3	2890	2890	100L-2	66/82
153	30	1,7	2,2	3214	2880	90L-2	88/81	149	42	2,25	3	3225	2890	100L-2	68/83
180	30	1,95	3	3673	2890	100L-2	64/88	176	40	2,6	4	3692	2905	112M-2	69/84
206	29	2,2	3	4128	2890	100L-2	65/85	203	40	2,92	4	4150	2905	112M-2	69/86
238	29	2,5	4	4668	2905	112M-2	66/87	233	39	3,3	4	4668	2905	112M-2	68/88
253	29	2,65	4	4923	2905	112M-2	54/88	250	39	3,52	5,5	4957	2925	132S-2	68/89
304	28	3,2	4	5810	2905	112M-2	87/106	302	38	4,2	5,5	5850	2925	132S-2	90/107

WPB 300															
Δ p = 500 mbar								Δ p = 600 mbar							
m³/h	Δ t (°C)	kW (erf)	kW (M)	min <sup>-1</sup>		IEC (M)	dB(A) (60) / (30)	m³/h	Δ t (°C)	kW (erf)	kW (M)	min <sup>-1</sup>		IEC (M)	dB(A) (60) / (30)
				G	M							G	M		
74	65	1,8	2,2	2035	2880	90L-2	62 / 79	70	83	2,1	3	2023	2890	100L-2	63 / 80
91	54	2	3	2312	2890	100L-2	64 / 81	88	76	2,4	3	2312	2890	100L-2	64 / 82
114	57	2,33	3	2697	2890	100L-2	65 / 82	105	62	2,7	4	2596	2905	112M-2	66 / 83
126	55	2,52	4	2905	2905	112M-2	66 / 83	123	68	3	4	2905	2905	112M-2	66 / 84
146	53	2,81	4	3242	2905	112M-2	69 / 84	144	65	3,4	5,5	3264	2925	132S-2	69 / 86
172	51	3,21	4	3692	2905	112M-2	70 / 86	171	63	3,9	5,5	3718	2925	132S-2	70 / 88
201	50	3,65	5,5	4178	2925	132S-2	70 / 88	198	61	4,4	5,5	4178	2925	132S-2	71 / 89
232	49	4,15	5,5	4700	2925	132S-2	70 / 90	229	59	4,95	7,5	4708	2930	132S-2	72 / 91
247	49	4,4	5,5	4957	2925	132S-2	70 / 91	244	59	5,2	7,5	4966	2930	132S-2	72 / 92
298	48	5,5	7,5	5860	2930	132S-2	92 / 107	296	58	6,2	7,5	5860	2930	132S-2	92 / 107

WPB 300															
Δ p = 700 mbar								Δ p = 800 mbar							
m³/h	Δ t (°C)	kW (erf)	kW (M)	min <sup>-1</sup>		IEC (M)	dB(A) (60) / (30)	m³/h	Δ t (°C)	kW (erf)	kW (M)	min <sup>-1</sup>		IEC (M)	dB(A) (60) / (30)
				G	M							G	M		
67	101	2,43	3	2023	2890	100L-2	64 / 81	83	108	3,2	4	2324	2905	112M-2	68 / 85
78	91	2,8	4	2324	2905	112M-2	66 / 83	100	100	3,6	5,5	2614	2925	132S-2	69 / 86
102	86	3,15	4	2596	2905	112M-2	66 / 84	119	94	4,05	5,5	2925	2925	132S-2	70 / 87
121	81	3,55	5,5	2925	2925	132S-2	67 / 85	139	90	4,5	5,5	3264	2925	132S-2	73 / 89
141	78	4	5,5	3264	2925	132S-2	70 / 87	166	86	5,2	7,5	3724	2930	132S-2	75 / 91
168	74	4,5	5,5	3718	2925	132S-2	72 / 90	193	83	5,8	7,5	4185	2930	132S-2	77 / 93
195	72	5,1	7,5	4185	2930	132S-2	74 / 91	225	81	6,6	11	4725	2940	160M-2	78 / 94
226	70	5,75	7,5	4708	2930	132S-2	77 / 93	239	80	6,92	11	4966	2930	160M-2	79 / 95
241	69	6,1	7,5	4966	2930	132S-2	78 / 94	273	78	7,8	11	5547	2940	160M-2	80 / 98
295	68	7,3	11	5880	2940	160M-2	93 / 107	293	78	8,3	11	5880	2940	160M-2	94 / 107

WPB 300															
Δ p = 900 mbar								Δ p = 1000 mbar							
m³/h	Δ t (°C)	kW (erf)	kW (M)	min <sup>-1</sup>		IEC (M)	dB(A) (60) / (30)	m³/h	Δ t (°C)	kW (erf)	kW (M)	min <sup>-1</sup>		IEC (M)	dB(A) (60) / (30)
				G	M							G	M		
98	115	4,1	5,5	2614	2925	132S-2	70 / 87								
116	108	4,55	5,5	2925	2925	132S-2	71 / 88								
137	103	5,1	7,5	3270	2930	132S-2	73 / 90	135	116	5,65	7,5	3270	2930	132S-2	76 / 92
164	98	5,8	7,5	3724	2930	132S-2	76 / 92	162	110	6,5	7,5	3724	2930	132S-2	77 / 93
192	94	6,55	11	4200	2940	160M-2	77 / 93	190	106	7,3	11	4200	2940	160M-2	79 / 95
223	92	7,4	11	4725	2940	160M-2	79 / 95	221	103	8,2	11	4725	2940	160M-2	82 / 99
238	91	7,8	11	4983	2940	160M-2	79 / 95	252	100	9,2	11	5250	2940	160M-2	86 / 102
271	89	8,8	11	5547	2940	160M-2	82 / 98								
290	88	9,3	11	5880	2940	160M-2	94 / 106								

Δ p (mbar)	Druckdifferenz	Pressure difference	Pression différentielle	Differenza di pressione
min <sup>-1</sup>	Drehzahl	Speed	Vitesse rotation	Numero giri
G / M	Gebläse / Motor	Blower / Motor	Turbine / Moteur	Soffiante / Motore
Δ t (°C)	Temperaturdifferenz	Temperature difference	Différence de température	Differenza di temperatura
kW (erf)	erforderliche Leistung	Capacity required	Puissance néssaire	Potenza necessaria
kW (M)	Motorleistung	Motor rating	Puissance moteur	Potenza motore
IEC (M)	IEC Motor-Baugröße	IEC Motor size	Série IEC de moteur	Grandezza IEC del motore
dB(A) → DIN 45635	Mittlerer Schalldruckpegel	Average noise level	Niveau sonore moyen	Rumorosità media

WPB 400															
Δ p = 300 mbar								Δ p = 400 mbar							
m³/h	Δ t (°C)	kW (erf)	kW (M)	min <sup>-1</sup>		IEC (M)	dB(A) (60) / (30)	m³/h	Δ t (°C)	kW (erf)	kW (M)	min <sup>-1</sup>		IEC (M)	dB(A) (60) / (30)
				G	M							G	M		
110	34	1,4	2,2	2035	2880	90L-2	61 / 79	105	48	1,82	2,2	2035	2880	90L-2	62 / 80
131	33	1,6	2,2	2312	2880	90L-2	61 / 79	126	45	2,1	3	2312	2890	100L-2	62 / 80
160	31	1,83	2,2	2688	2880	90L-2	62 / 79	155	43	2,42	3	2697	2890	100L-2	63 / 81
175	31	2	3	2890	2890	100L-2	63 / 79	171	42	2,6	4	2905	2905	112M-2	64 / 82
200	30	2,2	3	3225	2890	100L-2	66 / 83	196	41	2,93	4	3242	2905	112M-2	66 / 84
235	30	2,55	4	3692	2905	112M-2	67 / 85	232	40	3,4	5,5	3718	2925	132S-2	68 / 86
270	29	2,9	4	4150	2905	112M-2	68 / 87	267	39	3,82	5,5	4178	2925	132S-2	68 / 87
309	29	3,3	4	4668	2905	112M-2	68 / 88	306	39	4,33	5,5	4700	2925	132S-2	68 / 88
330	29	3,5	5,5	4957	2925	132S-2	68 / 89	325	39	4,6	5,5	4957	2925	132S-2	68 / 89
395	29	4,3	5,5	5850	2925	132S-2	72 / 96	390	39	5,5	7,5	5850	2925	132S-2	71 / 91

WPB 400															
Δ p = 500 mbar								Δ p = 600 mbar							
m³/h	Δ t (°C)	kW (erf)	kW (M)	min <sup>-1</sup>		IEC (M)	dB(A) (60) / (30)	m³/h	Δ t (°C)	kW (erf)	kW (M)	min <sup>-1</sup>		IEC (M)	dB(A) (60) / (30)
				G	M							G	M		
99	63	2,25	3	2023	2890	100L-2	62 / 80	96	79	2,7	4	2033	2905	112M-2	63 / 81
121	59	2,6	4	2324	2905	112M-2	62 / 80	118	73	3,1	4	2324	2905	112M-2	63 / 81
151	55	3,05	4	2711	2905	112M-2	64 / 82	140	69	3,5	5,5	2614	2925	132S-2	64 / 82
166	54	3,25	4	2905	2905	112M-2	64 / 82	164	66	3,9	5,5	2925	2925	132S-2	65 / 83
193	52	3,7	5,5	3264	2925	132S-2	66 / 84	190	64	4,4	5,5	3264	2925	132S-2	67 / 85
228	51	4,2	5,5	3718	2925	132S-2	68 / 86	224	62	5	7,5	3724	2930	132S-2	69 / 88
262	50	4,73	5,5	4178	2925	132S-2	69 / 88	259	60	5,7	7,5	4185	2930	132S-2	70 / 89
302	49	5,4	7,5	4708	2930	132S-2	70 / 89	299	59	6,4	7,5	4708	2930	132S-2	71 / 91
321	49	5,7	7,5	4957	2925	132S-2	70 / 90	319	59	6,8	11	4983	2940	160M-2	71 / 92
388	48	6,9	11	5880	2940	132S-2	73 / 94	385	58	8,2	11	5880	2940	160M-2	73 / 96

WPB 400															
Δ p = 700 mbar								Δ p = 800 mbar							
m³/h	Δ t (°C)	kW (erf)	kW (M)	min <sup>-1</sup>		IEC (M)	dB(A) (60) / (30)	m³/h	Δ t (°C)	kW (erf)	kW (M)	min <sup>-1</sup>		IEC (M)	dB(A) (60) / (30)
				G	M							G	M		
92	95	3,2	4	2033	2905	112M-2	65 / 82	89	112	3,6	5,5	2030	2925	132S-2	66 / 83
116	87	3,63	5,5	2340	2925	132S-2	65 / 83	110	103	4,1	5,5	2301	2925	132S-2	66 / 84
137	83	4,1	5,5	2614	2925	132S-2	66 / 84	131	97	4,6	5,5	2574	2925	132S-2	67 / 85
160	79	4,6	5,5	2925	2925	132S-2	66 / 84	158	92	5,2	7,5	2930	2930	132S-2	68 / 85
187	76	5,1	7,5	3270	2930	132S-2	68 / 86	184	88	5,85	7,5	3277	2930	132S-2	69 / 87
221	73	5,85	7,5	3724	2930	132S-2	70 / 89	219	84	6,7	11	3737	2940	160M-2	72 / 90
257	71	6,6	11	4200	2940	160M-2	71 / 90	254	82	7,55	11	4200	2940	160M-2	73 / 91
297	70	7,5	11	4725	2940	160M-2	72 / 92	294	80	8,5	11	4725	2940	160M-2	74 / 93
335	69	8,5	11	5250	2940	160M-2	74 / 94	333	79	9,5	11	5250	2940	160M-2	78 / 98
383	69	9,5	11	5880	2940	160M-2	76 / 101								

WPB 400															
Δ p = 900 mbar								Δ p = 1000 mbar							
m³/h	Δ t (°C)	kW (erf)	kW (M)	min <sup>-1</sup>		IEC (M)	dB(A) (60) / (30)	m³/h	Δ t (°C)	kW (erf)	kW (M)	min <sup>-1</sup>		IEC (M)	dB(A) (60) / (30)
				G	M							G	M		
106	119	4,6	5,5	2285	2925	132S-2	67 / 85								
129	111	5,2	7,5	2578	2930	132S-2	68 / 85								
156	104	5,9	7,5	2930	2930	132S-2	69 / 86	154	117	6,6	11	2940	2940	160M-2	70 / 88
183	100	6,6	11	3288	2940	160M-2	70 / 88	181	112	7,3	11	3288	2940	160M-2	72 / 90
217	96	7,5	11	3737	2940	160M-2	72 / 90	215	107	8,4	11	3737	2940	160M-2	73 / 91
252	93	8,5	11	4200	2940	160M-2	74 / 92	250	104	9,4	11	4200	2940	160M-2	76 / 95

m³/h	Volumenstrom	Capacity	Volume engendré	Portata volumetrica
------	--------------	----------	-----------------	---------------------

Der Volumenstrom bezieht sich auf freie atmosphärische Luft von 1 bar (abs.) und 20° C./ The capacity refers to free atmospheric air at 1 bar (abs.) and 20° C./ Le débit est mesuré à l'atmosphère de 1 bar (abs.) à 20° C./ La portata si riferisce alla pressione atmosferica di 1 bar (ass.) e 20° C.

Tabellenangaben beziehen sich auf betriebswarme Verdichter./ Tables refer to compressor at normal operating temperature./ Les tableaux sont établies, compresseur à température de fonctionnement./ I dati riportati nelle tabelle si riferiscono ai compressori con funzionamento a regime.

Technische Änderungen vorbehalten! / We reserve the right to alter technical information! / Sous réserve de modification technique! / Salvo modifiche tecniche!

WPB 430 / WPB 550															
Δ p = 300 mbar							Δ p = 400 mbar								
m³/h	Δ t (°C)	kW (erf)	kW (M)	min <sup>-1</sup>		IEC (M)	dB(A) (60) / (30)	m³/h	Δ t (°C)	kW (erf)	kW (M)	min <sup>-1</sup>		IEC (M)	dB(A) (60) / (30)
				G	M							G	M		
163	32	1,9	3	2006	2890	106	59 / 81	157	45	2,6	4	2016	2905	113	60 / 82
189	31	2,2	3	2244	2890	106	60 / 82	184	43	2,9	4	2256	2905	113	62 / 83
22	30	2,5	3	2550	2890	106	61 / 83	217	42	3,3	4	2563	2905	113	62 / 84
260	30	2,8	4	2905	2905	113	62 / 84	256	40	3,8	5,5	2925	2925	130	62 / 85
297	29	3,2	4	3247	2905	113	63 / 85	293	40	4,2	5,5	3269	2925	130	63 / 86
340	29	3,6	5,5	3648	2925	130	64 / 87	334	39	4,7	5,5	3648	2925	130	65 / 88
385	29	4	5,5	4061	2925	130	66 / 88	379	38	5,3	7,5	4068	2930	131	66 / 89
424	28	4,4	5,5	4432	2925	130	67 / 89	419	38	5,8	7,5	4439	2930	131	67 / 90
453	28	4,7	5,5	4698	2925	130	68 / 90	447	38	6,2	7,5	4706	2930	131	68 / 91
482	28	5	7,5	4972	2930	131	69 / 91	478	38	6,6	11	4989	2940	163	69 / 92
511	28	5,3	7,5	5239	2930	131	70 / 92	506	38	7,0	11	5256	2940	163	71 / 94

WPB 430 / WPB 550															
Δ p = 500 mbar							Δ p = 600 mbar								
m³/h	Δ t (°C)	kW (erf)	kW (M)	min <sup>-1</sup>		IEC (M)	dB(A) (60) / (30)	m³/h	Δ t (°C)	kW (erf)	kW (M)	min <sup>-1</sup>		IEC (M)	dB(A) (60) / (30)
				G	M							G	M		
152	59	3,2	4	2016	2905	113	60 / 83	148	72	3,9	5,5	2030	2925	130	61 / 84
179	56	3,6	5,5	2271	2925	130	62 / 83	174	69	4,3	5,5	2271	2925	130	63 / 84
213	53	4,1	5,5	2580	2925	130	63 / 85	208	66	4,9	7,5	2585	2930	131	63 / 86
250	52	4,7	5,5	2925	2925	130	63 / 86	246	63	5,6	7,5	2930	2930	131	63 / 87
288	50	5,3	7,5	3275	2930	131	64 / 87	283	61	6,3	7,5	3275	2930	131	64 / 88
329	49	5,9	7,5	3654	2930	131	65 / 89	325	60	7,1	11	3666	2940	163	66 / 89
375	48	6,6	11	4081	2940	163	66 / 90	370	59	7,9	11	4081	2940	163	67 / 91
415	48	7,2	11	4455	2940	163	67 / 91	410	58	8,6	11	4455	2940	163	68 / 92
444	48	7,7	11	4722	2940	163	68 / 92	439	58	9,2	11	4722	2940	163	69 / 93
472	47	8,2	11	4989	2940	163	69 / 93	468	57	9,8	15	4989	2940	164	70 / 94
501	47	8,7	11	5256	2940	163	71 / 95	497	57	10,3	15	5256	2940	164	72 / 96

WPB 430 / WPB 550															
Δ p = 700 mbar							Δ p = 800 mbar								
m³/h	Δ t (°C)	kW (erf)	kW (M)	min <sup>-1</sup>		IEC (M)	dB(A) (60) / (30)	m³/h	Δ t (°C)	kW (erf)	kW (M)	min <sup>-1</sup>		IEC (M)	dB(A) (60) / (30)
				G	M							G	M		
143	87	4,5	5,5	2030	2925	130	61 / 84	140	102	5,1	7,5	2034	2930	131	61 / 85
170	82	5,0	7,5	2275	2930	131	63 / 85	166	96	5,8	7,5	2275	2930	131	64 / 86
204	78	5,7	7,5	2585	2930	131	64 / 86	201	91	6,6	11	2594	2940	163	64 / 87
243	75	6,5	11	2940	2940	163	64 / 87	239	87	7,5	11	2940	2940	163	65 / 88
280	72	7,3	11	3286	2940	163	65 / 88	276	84	8,4	11	3286	2940	163	65 / 89
321	71	8,2	11	3666	2940	163	68 / 90	318	82	9,4	11	3666	2940	163	66 / 90
366	69	9,2	11	4081	2940	163	67 / 91	362	80	10,5	15	4081	2940	164	67 / 92
406	68	10,1	15	4455	2940	164	68 / 93	403	78	11,5	15	4455	2940	164	68 / 93
435	68	10,7	15	4722	2940	164	69 / 94	432	78	12,2	15	4722	2940	164	69 / 94
464	67	11,3	15	4989	2940	164	70 / 95	460	77	12,9	15	4989	2940	164	70 / 95
493	67	12,0	15	5256	2940	164	73 / 97	489	77	13,6	18,5	5256	2940	166	74 / 98

WPB 430 / WPB 550															
Δ p = 900 mbar							Δ p = 1000 mbar								
m³/h	Δ t (°C)	kW (erf)	kW (M)	min <sup>-1</sup>		IEC (M)	dB(A) (60) / (30)	m³/h	Δ t (°C)	kW (erf)	kW (M)	min <sup>-1</sup>		IEC (M)	dB(A) (60) / (30)
				G	M							G	M		
137	118	5,8	7,5	2034	2930	131	61 / 85								
163	110	6,5	7,5	2275	2930	131	64 / 86								
198	104	7,4	11	2594	2940	163	64 / 87	195	117	8,2	11	2594	2940	163	65/89
236	99	8,4	11	2940	2940	163	65 / 88	233	111	9,3	11	2940	2940	163	66/91
273	95	9,4	11	3286	2940	163	65 / 89	270	107	10,4	15	3286	2940	164	67/92
314	93	10,5	15	3666	2940	164	66 / 91	312	104	11,7	15	3666	2940	164	69/94
359	90	11,7	15	4081	2940	164	67 / 92	356	111	13,0	18,5	4081	2940	166	70/96
400	89	12,9	15	4455	2940	164	68 / 93	397	99	14,3	18,5	4455	2940	166	71/98
428	88	13,7	18,5	4722	2940	166	69 / 94	426	98	15,2	18,5	4722	2940	166	73/100
457	87	14,5	18,5	4989	2940	166	70 / 95								
486	86	15,3	18,5	5256	2940	166	75 / 99								

Δ p (mbar)	Druckdifferenz	Pressure difference	Pression différentielle	Differenza di pressione
min <sup>-1</sup>	Drehzahl	Speed	Vitesse rotation	Numero giri
G / M	Gebälse / Motor	Blower / Motor	Turbine / Moteur	Soffiante / Motore
Δ t (°C)	Temperaturdifferenz	Temperature difference	Différence de température	Differenza di temperatura
kW (erf)	erforderliche Leistung	Capacity required	Puissance néssaire	Potenza necessaria
kW (M)	Motorleistung	Motor rating	Puissance moteur	Potenza motore
IEC (M)	IEC Motor-Baugröße	IEC Motor size	Série IEC de moteur	Grandezza IEC del motore
dB(A) → DIN 45635	Mittlerer Schalldruckpegel	Average noise level	Niveau sonore moyen	Rumorosità media

WPB 750															
$\Delta p = 300 \text{ mbar}$								$\Delta p = 400 \text{ mbar}$							
m <sup>3</sup> /h	$\Delta t$ (°C)	kW (erf)	kW (M)	min <sup>-1</sup>		IEC (M)	dB(A) (60) / (30)	m <sup>3</sup> /h	$\Delta t$ (°C)	kW (erf)	kW (M)	min <sup>-1</sup>		IEC (M)	dB(A) (60) / (30)
				G	M							G	M		
229	32	2,7	4	2016	2905	113	60 / 84	223	44	3,5	5,5	2030	2925	130	61 / 85
264	31	3,0	4	2256	2905	113	61 / 85	258	43	4,0	5,5	2271	2925	130	62 / 86
312	30	3,4	5,5	2581	2925	130	62 / 86	304	41	4,5	5,5	2581	2925	130	63 / 87
362	30	4,0	5,5	2925	2925	130	63 / 87	355	40	5,2	7,5	2930	2930	131	64 / 88
413	29	4,4	5,5	3269	2925	130	65 / 88	406	40	5,8	7,5	3275	2930	131	65 / 89
469	29	5,0	7,5	3654	2930	131	66 / 90	463	39	6,6	11	3666	2940	163	66 / 90
530	29	5,6	7,5	4068	2930	131	67 / 91	524	39	7,4	11	4081	2940	163	67 / 92
584	29	6,2	7,5	4439	2930	131	67 / 92	578	39	8,2	11	4455	2940	163	67 / 92
625	29	6,7	11	4722	2940	163	68 / 93	617	39	8,7	11	4722	2940	163	69 / 93
664	29	7,2	11	4989	2940	163	69 / 94	656	39	9,3	11	4989	2940	163	70 / 95

WPB 750															
$\Delta p = 500 \text{ mbar}$								$\Delta p = 600 \text{ mbar}$							
m <sup>3</sup> /h	$\Delta t$ (°C)	kW (erf)	kW (M)	min <sup>-1</sup>		IEC (M)	dB(A) (60) / (30)	m <sup>3</sup> /h	$\Delta t$ (°C)	kW (erf)	kW (M)	min <sup>-1</sup>		IEC (M)	dB(A) (60) / (30)
				G	M							G	M		
215	57	4,4	5,5	2030	2925	130	61 / 85	210	70	5,3	7,5	2034	2930	131	61 / 86
252	55	5,0	7,5	2275	2930	131	62 / 86	245	67	6,0	7,5	2275	2930	131	63 / 87
297	53	5,6	7,5	2585	2930	131	63 / 87	293	64	6,8	11	2594	2940	163	64 / 88
348	51	6,4	7,5	2930	2930	131	64 / 88	344	62	7,7	11	2940	2940	163	65 / 88
400	50	7,3	11	3286	2940	163	65 / 89	395	61	8,7	11	3286	2940	163	66 / 90
456	49	8,1	11	3666	2940	163	66 / 91	450	59	9,7	15	3666	2940	164	67 / 91
517	49	9,1	11	4081	2940	163	67 / 92	511	59	10,9	15	4081	2940	164	69 / 93
572	48	10,1	15	4455	2940	164	67 / 92	566	58	12,0	15	4455	2940	164	69 / 93
611	48	10,7	15	4722	2940	164	69 / 94	605	58	12,7	15	4722	2940	164	70 / 94
650	48	11,4	15	4989	2940	164	70 / 95	644	58	13,5	18,5	4989	2940	166	72 / 96

WPB 750															
$\Delta p = 700 \text{ mbar}$								$\Delta p = 800 \text{ mbar}$							
m <sup>3</sup> /h	$\Delta t$ (°C)	kW (erf)	kW (M)	min <sup>-1</sup>		IEC (M)	dB(A) (60) / (30)	m <sup>3</sup> /h	$\Delta t$ (°C)	kW (erf)	kW (M)	min <sup>-1</sup>		IEC (M)	dB(A) (60) / (30)
				G	M							G	M		
104	84	6,1	7,5	2034	2930	131	62 / 86	201	98	7,1	11	2043	2940	163	62 / 87
100	80	7,0	11	2283	2940	163	63 / 87	237	93	7,9	111	2283	2940	163	63 / 88
96	76	7,9	11	2594	2940	163	64 / 88	283	88	9	11	2594	2940	163	65 / 89
93	73	9,0	11	2940	2940	163	65 / 89	334	85	10,2	15	2940	2940	164	66 / 90
91	71	10,1	15	3286	2940	164	66 / 90	385	82	11,5	15	3286	2940	164	67 / 91
90	70	11,3	15	3666	2940	164	68 / 92	441	81	12,8	15	3666	2940	164	68 / 92
89	69	12,6	15	4081	2940	164	69 / 93	502	79	14,4	18,5	4081	2940	166	70 / 94
88	68	13,9	18,5	4455	2940	166	69 / 93	557	78	15,8	18,5	4455	2940	166	70 / 94
88	68	14,8	18,5	4722	2940	166	71 / 95	597	77	16,8	22	4730	2945	183	72 / 96
87	67	15,7	18,5	4989	2940	166	72 / 96	637	77	17,9	22	4998	2945	183	73 / 96

WPB 750															
$\Delta p = 900 \text{ mbar}$															
m <sup>3</sup> /h	$\Delta t$ (°C)	kW (erf)	kW (M)	min <sup>-1</sup>		IEC (M)	dB(A) (60) / (30)	m <sup>3</sup> /h	$\Delta t$ (°C)	kW (erf)	kW (M)	min <sup>-1</sup>		IEC (M)	dB(A) (60) / (30)
				G	M							G	M		
197	112	7,9	11	2043	2940	163	62 / 88								
233	106	8,9	11	2283	2940	163	64 / 88								
279	101	10,1	15	2594	2940	164	65 / 89								
330	96	11,5	15	2940	2940	164	66 / 90								
381	94	12,9	15	3286	2940	164	67 / 91								
437	91	14,4	18,5	3666	2940	166	69 / 93								
499	89	16,2	22	4088	2945	183	70 / 94								
554	88	17,7	22	4462	2945	183	70 / 94								
594	87	18,9	22	4730	2945	183	73 / 97								

m <sup>3</sup> /h	Volumenstrom	Capacity	Volume engendré	Portata volumetrica
-------------------	--------------	----------	-----------------	---------------------

Der Volumenstrom bezieht sich auf freie atmosphärische Luft von 1 bar (abs.) und 20° C./ The capacity refers to free atmospheric air at 1 bar (abs.) and 20° C./ Le débit est mesuré à l'atmosphère de 1 bar (abs.) à 20° C./ La portata si riferisce alla pressione atmosferica di 1 bar (ass.) e 20° C.

Tabellenangaben beziehen sich auf betriebswarme Verdichter./ Tables refer to compressor at normal operating temperature./ Les tableaux sont établies, compresseur à température de fonctionnement./ I dati riportati nelle tabelle si riferiscono ai compressori con funzionamento a regime.

Technische Änderungen vorbehalten! / We reserve the right to alter technical information! / Sous réserve de modification technique! / Salvo modifiche tecniche!

WPB 780 / WPB 1000															
Δ p = 300 mbar								Δ p = 400 mbar							
m³/h	Δ t (°C)	kW (erf)	kW (M)	min <sup>-1</sup>		IEC (M)	dB(A) (60) / (30)	m³/h	Δ t (°C)	kW (erf)	kW (M)	min <sup>-1</sup>		IEC (M)	dB(A) (60) / (30)
				G	M							G	M		
396	31	4,4	5,5	2184	2925	130	67 / 88	386	42	5,8	7,5	2188	2930	131	67 / 88
462	30	5,1	7,5	2486	2930	131	67 / 88	455	41	6,7	11	2499	2940	163	67 / 89
560	29	6,0	7,5	2930	2930	131	68 / 90	552	40	7,9	11	2940	2940	163	68 / 91
648	29	6,9	11	3332	2940	163	69 / 91	638	39	9,1	11	3332	2940	163	70 / 93
734	29	7,8	11	3724	2940	163	70 / 92	724	39	10,2	15	3724	2940	164	71 / 93
777	29	8,3	11	3920	2940	163	71 / 92	767	39	10,8	15	3920	2940	164	72 / 94
829	29	8,9	11	4155	2940	163	71 / 92	819	38	11,5	15	4155	2940	164	72 / 94
880	29	9,4	11	4390	2940	163	72 / 93	870	38	12,3	15	4390	2940	164	73 / 95
953	29	10,3	15	4722	2940	164	73 / 94	943	38	13,3	18,5	4722	2940	166	74 / 95
1011	29	11,0	15	4989	2940	164	74 / 95	1002	38	14,2	18,5	4989	2940	166	75 / 96
1070	29	11,7	15	5256	2940	164	75 / 96	1060	39	15,1	18,5	5256	2940	166	76 / 97

WPB 780 / WPB 1000															
Δ p = 500 mbar								Δ p = 600 mbar							
m³/h	Δ t (°C)	kW (erf)	kW (M)	min <sup>-1</sup>		IEC (M)	dB(A) (60) / (30)	m³/h	Δ t (°C)	kW (erf)	kW (M)	min <sup>-1</sup>		IEC (M)	dB(A) (60) / (30)
				G	M							G	M		
381	53	7,3	11	2205	2940	163	67 / 89	373	65	8,7	11	2205	2940	163	68 / 91
446	51	8,3	11	2499	2940	163	68 / 91	438	63	9,9	15	2499	2940	164	68 / 92
543	50	9,8	15	2940	2940	164	69 / 93	536	60	11,7	15	2940	2940	164	69 / 93
629	49	11,2	15	3332	2940	164	71 / 94	622	59	13,4	18,5	3332	2940	166	71 / 95
716	48	12,6	15	3724	2940	164	72 / 95	708	58	15,0	18,5	3724	2940	166	73 / 95
759	48	13,3	18,5	3920	2940	166	73 / 95	752	58	15,9	18,5	3920	2940	166	74 / 96
810	48	14,2	18,5	4155	2940	166	73 / 95	805	58	16,9	22	4162	2945	183	74 / 96
862	48	15,1	18,5	4390	2940	166	74 / 96	857	57	18,0	22	4398	2945	183	75 / 96
937	48	16,4	22	4730	2945	183	75 / 96	931	57	19,5	30	4738	2950	206	76 / 96
995	48	17,5	22	4998	2945	183	75 / 97	990	57	20,7	30	5006	2950	206	76 / 97

WPB 780 / WPB 1000															
Δ p = 700 mbar								Δ p = 800 mbar							
m³/h	Δ t (°C)	kW (erf)	kW (M)	min <sup>-1</sup>		IEC (M)	dB(A) (60) / (30)	m³/h	Δ t (°C)	kW (erf)	kW (M)	min <sup>-1</sup>		IEC (M)	dB(A) (60) / (30)
				G	M							G	M		
367	77	10,2	15	2205	2940	164	68 / 92	361	89	11,6	15	2205	2940	164	68 / 92
432	74	11,5	15	2499	2940	164	68 / 92	426	86	13,1	18,5	2499	2940	166	69 / 93
529	71	13,6	18,5	2940	2940	166	69 / 93	524	82	15,5	18,5	2940	2940	166	70 / 94
616	70	15,5	18,5	3332	2940	166	71 / 95	612	80	17,7	22	3338	2945	183	72 / 96
703	68	17,5	22	3730	2945	183	73 / 96	687	79	19,6	30	3679	2950	206	73 / 96
747	68	18,5	22	3927	2945	183	73 / 96	743	78	21,1	30	3933	2950	206	74 / 96
800	67	19,7	30	4169	2950	206	74 / 96	795	77	22,4	30	4169	2950	206	74 / 97
852	67	20,9	30	4405	2950	206	75 / 97	847	77	23,8	30	4405	2950	206	75 / 97
925	67	22,6	30	4738	2950	206	76 / 97	920	76	25,7	30	4738	2950	206	77 / 98
984	67	24,0	30	5006	2950	206	76 / 98	979	76	27,3	37	5006	2950	207	78 / 98

WPB 780 / WPB 1000															
Δ p = 900 mbar								Δ p = 1000 mbar							
m³/h	Δ t (°C)	kW (erf)	kW (M)	min <sup>-1</sup>		IEC (M)	dB(A) (60) / (30)	m³/h	Δ t (°C)	kW (erf)	kW (M)	min <sup>-1</sup>		IEC (M)	dB(A) (60) / (30)
				G	M							G	M		
356	101	13,0	18,5	2205	2940	166	69 / 93	352	114	14,4	18,5	2205	2940	166	69 / 93
421	97	14,8	18,5	2499	2940	166	69 / 93	418	109	16,4	22	2503	2945	183	70 / 94
520	93	17,5	22	2945	2945	183	70 / 94	517	104	19,4	30	2950	2950	206	72 / 96
596	91	19,6	30	3292	2950	206	72 / 96	592	101	21,7	30	3292	2950	206	73 / 97
682	89	22,0	30	3679	2950	206	74 / 97	678	99	24,4	30	3679	2950	206	74 / 97
728	88	23,3	30	3887	2950	206	74 / 97	724	98	25,9	30	3887	2950	206	75 / 97
774	87	24,7	30	4095	2950	206	75 / 97	769	98	27,3	37	4095	2950	207	76 / 97
842	87	26,6	37	4405	2950	207	76 / 98	838	97	29,5	37	4405	2950	207	77 / 98
894	86	28,2	37	4641	2950	207	77 / 99	890	96	31,2	37	4641	2950	207	78 / 99
974	86	30,6	37	5006	2950	207	78 / 100								

Δ p (mbar)	Druckdifferenz	Pressure difference	Pression différentielle	Differenza di pressione
min <sup>-1</sup>	Drehzahl	Speed	Vitesse rotation	Numero giri
G / M	Gebälse / Motor	Blower / Motor	Turbine / Moteur	Soffiante / Motore
Δ t (°C)	Temperaturdifferenz	Temperature difference	Différence de température	Differenza di temperatura
kW (erf)	erforderliche Leistung	Capacity required	Puissance néssaire	Potenza necessaria
kW (M)	Motorleistung	Motor rating	Puissance moteur	Potenza motore
IEC (M)	IEC Motor-Baugröße	IEC Motor size	Série IEC de moteur	Grandezza IEC del motore
dB(A) → DIN 45635	Mittlerer Schalldruckpegel	Average noise level	Niveau sonore moyen	Rumorosità media

WPB 1300															
Δ p = 300 mbar							Δ p = 400 mbar								
m³/h	Δ t (°C)	kW (erf)	kW (M)	min <sup>-1</sup>		IEC (M)	dB(A) (60) / (30)	m³/h	Δ t (°C)	kW (erf)	kW (M)	min <sup>-1</sup>		IEC (M)	dB(A) (60) / (30)
				G	M							G	M		
524	31	5,9	7,5	2185	2930	132	65 / 89	515	42	7,7	11	2195	2940	160	66 / 90
574	31	6,3	7,5	2355	2940	160	65 / 90	561	42	8,3	11	2355	2940	160	67 / 91
651	30,5	7,1	11	2625	2940	160	66 / 91	639	41	9,3	11	2625	2940	160	68 / 92
742	30	8	11	2940	2940	160	67 / 91	729	40,5	10,5	15	2940	2940	160	68 / 93
786	30	8,5	11	3095	2940	160	68 / 92	774	40	11,1	15	3095	2940	160	69 / 94
839	30	9,1	11	3280	2940	160	70 / 93	823	40	11,8	15	3265	2940	160	70 / 94
952	30	10,4	15	3675	2940	160	71 / 93	940	40	13,5	18,5	3675	2940	160	71 / 95
1028	30	11,3	15	3940	2940	160	72 / 94	1016	40	14,6	18,5	3940	2940	160	72 / 96
1087	30	12	15	4145	2940	160	73 / 95	1075	40	15,4	18,5	4145	2940	160	73 / 96
1208	29	13,5	18,5	4570	2940	160	74 / 96	1197	40	17,3	22	4570	2940	180	74 / 97

WPB 1300															
Δ p = 500 mbar							Δ p = 600 mbar								
m³/h	Δ t (°C)	kW (erf)	kW (M)	min <sup>-1</sup>		IEC (M)	dB(A) (60) / (30)	m³/h	Δ t (°C)	kW (erf)	kW (M)	min <sup>-1</sup>		IEC (M)	dB(A) (60) / (30)
				G	M							G	M		
505	54	9,6	15	2195	2940	160	66 / 90	496	65	11,4	15	2195	2940	160	67 / 91
551	53	10,3	15	2355	2940	160	67 / 91	542	64	12,3	15	2355	2940	160	68 / 92
629	52	11,5	15	2625	2940	160	68 / 92	620	63	13,8	18,5	2625	2940	160	68 / 93
719	51	13	18,5	2940	2940	160	69 / 93	711	61	15,5	18,5	2940	2940	160	69 / 93
764	51	13,7	18,5	3095	2940	160	70 / 94	755	61	16,3	22	3095	2940	180	70 / 94
816	50	14,6	18,5	3275	2940	160	71 / 94	807	60	17,4	22	3275	2940	180	71 / 95
930	50	16,6	22	3675	2940	180	72 / 95	922	60	19,7	30	3675	2950	200	72 / 96
1007	50	17,9	22	3940	2940	180	73 / 95	998	59	21,2	30	3940	2950	200	74 / 96
1065	50	19	30	4145	2950	200	74 / 95	1057	59	22,5	30	4145	2950	200	75 / 97
1187	50	21,2	30	4570	2950	200	75 / 96	1179	59	25	30	4570	2950	200	76 / 97

WPB 1300															
Δ p = 700 mbar							Δ p = 800 mbar								
m³/h	Δ t (°C)	kW (erf)	kW (M)	min <sup>-1</sup>		IEC (M)	dB(A) (60) / (30)	m³/h	Δ t (°C)	kW (erf)	kW (M)	min <sup>-1</sup>		IEC (M)	dB(A) (60) / (30)
				G	M							G	M		
489	77	13,3	18,5	2200	2940	160	67/92	483	89	15,2	22	2200	2950	180	68 / 92
534	75	14,2	18,5	2355	2940	160	68/92	531	87	16,3	22	2365	2950	180	69 / 93
612	74	16	22	2625	2950	180	69/93	606	85	18,2	30	2625	2950	200	70 / 94
706	72	18	22	2950	2950	180	70/95	700	83	20,5	30	2950	2950	200	70 / 94
748	71	19	30	3095	2950	200	70/95	741	82	21,6	30	3095	2950	200	71 / 95
804	71	20,2	30	3290	2950	200	71/95	798	81	23	30	3290	2950	200	72 / 96
915	70	22,8	30	3675	2950	200	73/96	909	80	25,9	37	3675	2950	200	73 / 97
991	69	24,6	30	3940	2950	200	74/96	985	79	27,9	37	3940	2950	200	74 / 98
1050	69	26	37	4145	2950	200	75/97	1044	79	29,5	37	4145	2950	200	75 / 98
1172	69	28,9	37	4570	2950	200	75/97								

WPB 1300															
Δ p = 900 mbar							Δ p = 1000 mbar								
m³/h	Δ t (°C)	kW (erf)	kW (M)	min <sup>-1</sup>		IEC (M)	dB(A) (60) / (30)	m³/h	Δ t (°C)	kW (erf)	kW (M)	min <sup>-1</sup>		IEC (M)	dB(A) (60) / (30)
				G	M							G	M		
477	101	17,0	22	2200	2950	180	69 / 92	473	113	19,2	30	2200	2950	200	70 / 95
525	99	18,3	30	2365	2950	200	69 / 92	520	111	21	30	2365	2950	200	71 / 96
600	96	20,4	30	2625	2950	200	70 / 93	596	107	22,6	30	2625	2950	200	72 / 96
694	94	23	30	2950	2950	200	71 / 94	689	104	25,5	37	2950	2950	200	72 / 96
736	93	24,2	30	3095	2950	200	72 / 95	731	103	26,8	37	3095	2950	200	73 / 96
792	92	26	37	3290	2950	200	73 / 96	788	101	28,6	37	3290	2950	200	74 / 97
903	90	30	37	3675	2950	200	74 / 96								
979	89	31,2	37	3940	2950	200	75 / 97								

m³/h	Volumenstrom	Capacity	Volume engendré	Portata volumetrica
------	--------------	----------	-----------------	---------------------

Der Volumenstrom bezieht sich auf freie atmosphärische Luft von 1 bar (abs.) und 20° C./ The capacity refers to free atmospheric air at 1 bar (abs.) and 20° C./ Le débit est mesuré à l'atmosphère de 1 bar (abs.) à 20° C./ La portata si riferisce alla pressione atmosferica di 1 bar (ass.) e 20° C.

Tabellenangaben beziehen sich auf betriebswarme Verdichter./ Tables refer to compressor at normal operating temperature./ Les tableaux sont établies, compresseur à température de fonctionnement./ I dati riportati nelle tabelle si riferiscono ai compressori con funzionamento a regime.

Technische Änderungen vorbehalten! / We reserve the right to alter technical information! / Sous réserve de modification technique! / Salvo modifiche tecniche!



WPB 1600															
Δ p = 300 mbar								Δ p = 400 mbar							
m³/h	Δ t (°C)	kW (erf)	kW (M)	min <sup>-1</sup>		IEC (M)	dB(A) (60) / (30)	m³/h	Δ t (°C)	kW (erf)	kW (M)	min <sup>-1</sup>		IEC (M)	dB(A) (60) / (30)
				G	M							G	M		
585	32	6,6	11	1395	1465	160	64 / 86	567	44	8,8	11	1395	1465	160	65 / 87
659	31	7,3	11	1538	1465	160	64 / 86	642	43	9,7	15	1538	1465	160	65 / 87
708	31	7,8	11	1632	1465	160	65 / 87	691	42	10,3	15	1632	1465	160	66 / 88
812	30	8,2	11	1831	1465	160	66 / 88	795	41	11,2	15	1831	1465	160	67 / 89
945	30	10	15	2085	2940	160	67 / 89	928	40	13,2	18,5	2085	2940	160	67 / 89
997	30	10,6	15	2185	2940	160	68 / 90	980	40	13,9	18,5	2185	2940	160	68 / 90
1085	29	11,4	15	2355	2940	160	70 / 92	1068	39	15	18,5	2355	2940	160	69 / 91
1226	29	12,8	18,5	2625	2940	160	71 / 93	1209	39	16,8	22	2625	2940	180	70 / 92
1390	29	14,5	18,5	2940	2940	160	72 / 94	1373	39	19	30	2940	2940	200	72 / 94

WPB 1600															
Δ p = 500 mbar								Δ p = 600 mbar							
m³/h	Δ t (°C)	kW (erf)	kW (M)	min <sup>-1</sup>		IEC (M)	dB(A) (60) / (30)	m³/h	Δ t (°C)	kW (erf)	kW (M)	min <sup>-1</sup>		IEC (M)	dB(A) (60) / (30)
				G	M							G	M		
552	56	10,9	15	1395	1465	160	65 / 87	540	68	13,0	18,5	1395	1465	180	66 / 88
627	54	12	15	1538	1465	160	66 / 88	615	66	14,4	18,5	1538	1465	180	67 / 89
676	53	12,8	15	1632	1465	160	66 / 88	664	65	15,3	18,5	1632	1465	180	68 / 90
781	52	14	18,5	1831	1465	180	67 / 89	769	63	17,1	22	1831	1465	180	68 / 90
913	51	16,4	22	2085	2940	180	68 / 90	901	61	19,6	30	2085	2940	200	69 / 91
966	50	17,2	22	2185	2940	180	69 / 91	954	61	20,6	30	2185	2940	200	62 / 92
1054	50	18,6	22	2355	2940	180	70 / 92	1043	60	22,2	30	2355	2940	200	70 / 93
1195	49	20,8	30	2625	2940	200	71 / 93	1184	59	24,9	30	2625	2940	200	71 / 94
1360	48	23,5	30	2940	2940	200	72 / 94	1348	58	28	37	2940	2940	200	72 / 95

WPB 1600															
Δ p = 700 mbar								Δ p = 800 mbar							
m³/h	Δ t (°C)	kW (erf)	kW (M)	min <sup>-1</sup>		IEC (M)	dB(A) (60) / (30)	m³/h	Δ t (°C)	kW (erf)	kW (M)	min <sup>-1</sup>		IEC (M)	dB(A) (60) / (30)
				G	M							G	M		
529	81	15,2	22	1395	1465	180	67 / 88	521	94	17,3	22	1395	1465	180	68 / 89
605	78	16,7	22	1538	1465	180	68 / 89	596	91	19,1	30	1538	1465	200	69 / 90
654	77	17,8	22	1632	1465	180	69 / 90	645	89	20,2	30	1632	1465	200	70 / 91
787	75	20	30	1885	1465	200	70 / 91	750	85	23	30	1831	1465	200	71 / 92
891	72	22,8	30	2085	2940	200	71 / 92	883	83	26	37	2085	2940	200	72 / 93
944	72	24	30	2185	2940	200	72 / 93	935	82	27,3	37	2185	2940	200	73 / 94
1033	71	26	37	2355	2940	200	73 / 94	1024	81	29,5	37	2355	2940	200	73 / 94
1174	69	30,1	37	2625	2940	200	73 / 95								

WPB 1600															
Δ p = 900 mbar								Δ p = 1000 mbar							
m³/h	Δ t (°C)	kW (erf)	kW (M)	min <sup>-1</sup>		IEC (M)	dB(A) (60) / (30)	m³/h	Δ t (°C)	kW (erf)	kW (M)	min <sup>-1</sup>		IEC (M)	dB(A) (60) / (30)
				G	M							G	M		
514	108	19,4	30	1395	1465	200	67 / 89	505	121	21,6	30	1395	1465	200	68 / 90
589	103	21,4	30	1538	1465	200	67 / 89	583	116	23,8	30	1538	1465	200	68 / 91
638	101	22,8	30	1632	1465	200	68 / 90	632	113	25,3	30	1632	1465	200	69 / 92
742	97	25,6	37	1831	1465	200	69 / 91	743	108	28,6	37	1843	1475	200	69 / 92
875	94	29,2	37	2085	2940	200	69 / 91	803	105	30,5	37	1960	2940	200	69 / 92
928	93	30,6	37	2185	2940	200	70 / 92								

Δ p (mbar)	Druckdifferenz	Pressure difference	Pression différentielle	Differenza di pressione
min <sup>-1</sup>	Drehzahl	Speed	Vitesse rotation	Numero giri
G / M	Gebälse / Motor	Blower / Motor	Turbine / Moteur	Soffiante / Motore
Δ t (°C)	Temperaturdifferenz	Temperature difference	Différence de température	Differenza di temperatura
kW (erf)	erforderliche Leistung	Capacity required	Puissance néssaire	Potenza necessaria
kW (M)	Motorleistung	Motor rating	Puissance moteur	Potenza motore
IEC (M)	IEC Motor-Baugröße	IEC Motor size	Série IEC de moteur	Grandezza IEC del motore
dB(A) → DIN 45635	Mittlerer Schalldruckpegel	Average noise level	Niveau sonore moyen	Rumorosità media

WPB 2000															
Δ p = 300 mbar							Δ p = 400 mbar								
m³/h	Δ t (°C)	kW (erf)	kW (M)	min <sup>-1</sup>		IEC (M)	dB(A) (60) / (30)	m³/h	Δ t (°C)	kW (erf)	kW (M)	min <sup>-1</sup>		IEC (M)	dB(A) (60) / (30)
				G	M							G	M		
691	32	7,9	11	1378	1460	160	85 / 63	671	45	10,4	15	1378	1460	160	86 / 64
742	31	8,3	11	1460	1460	160	86 / 64	722	43	11	15	1460	1460	160	87 / 65
847	31	9,3	11	1629	1460	160	86 / 64	827	42	12,3	15	1629	1460	160	87 / 65
997	30	10,8	15	1880	2925	160	87 / 65	981	41	14,2	18,5	1887	2935	160	88 / 66
1070	30	11,5	15	1985	2925	160	88 / 66	1055	40	15,1	18,5	1992	2935	160	89 / 67
1142	30	12,2	15	2106	2925	160	89 / 67	1132	40	16,1	22	2120	2945	180	89 / 67
1215	29	12,9	15	2223	2925	160	89 / 67	1205	40	17,1	22	2238	2945	180	90 / 68
1292	29	13,7	18,5	2348	2935	160	90 / 68	1278	39	18	22	2356	2945	180	91 / 69
1467	29	15,4	18,5	2630	2935	160	92 / 70	1456	39	20,3	30	2643	2950	200	92 / 70
1661	29	17,5	22	2945	2945	180	94 / 72	1646	39	22,9	30	2950	2950	200	94 / 72

WPB 2000															
Δ p = 500 mbar							Δ p = 600 mbar								
m³/h	Δ t (°C)	kW (erf)	kW (M)	min <sup>-1</sup>		IEC (M)	dB(A) (60) / (30)	m³/h	Δ t (°C)	kW (erf)	kW (M)	min <sup>-1</sup>		IEC (M)	dB(A) (60) / (30)
				G	M							G	M		
654	58	12,8	15	1378	1460	160	86 / 64	641	68	15,4	18,5	1378	1460	160	87 / 65
705	54	13,6	18,5	1460	1460	160	87 / 65	695	66	16,3	22	1465	1465	180	88 / 66
811	53	15,2	18,5	1629	1460	160	87 / 65	801	64	18,3	22	1635	1465	180	88 / 66
975	51	17,8	22	1893	2945	180	88 / 66	963	62	21,2	30	1896	2950	200	89 / 67
1040	50	18,8	22	1998	2945	180	89 / 67	1029	61	22,5	30	2002	2950	200	90 / 68
1118	50	20	30	2124	2950	200	90 / 68	1105	61	23,9	30	2124	2950	200	90 / 68
1191	50	21,2	30	2242	2950	200	90 / 68	1178	60	25,2	30	2242	2950	200	91 / 69
1265	49	22,3	30	2360	2950	200	91 / 69	1251	59	26,6	37	2360	2950	200	92 / 70
1440	49	25,1	30	2643	2950	200	93 / 71	1427	59	30	37	2643	2950	200	93 / 71
1630	48	28,3	37	2950	2950	200	95 / 73	1620	58	33,7	45	2955	2955	225	95 / 73

WPB 2000															
Δ p = 700 mbar							Δ p = 800 mbar								
m³/h	Δ t (°C)	kW (erf)	kW (M)	min <sup>-1</sup>		IEC (M)	dB(A) (60) / (30)	m³/h	Δ t (°C)	kW (erf)	kW (M)	min <sup>-1</sup>		IEC (M)	dB(A) (60) / (30)
				G	M							G	M		
632	84	17,9	22	1383	1465	180	87 / 65	622	95	20,4	30	1383	1465	200	87 / 65
683	78	19	22	1465	1465	180	88 / 66	674	90	21,6	30	1465	1465	200	88 / 66
789	75	21,2	30	1635	1465	200	89 / 67	780	87	24,2	30	1635	1465	200	89 / 67
952	73	24,7	30	1896	2950	200	89 / 67	942	84	28,1	37	1896	2950	200	90 / 68
1018	72	26,1	37	2002	2950	200	90 / 68	1008	83	29,7	37	2002	2950	200	90 / 68
1094	71	27,7	37	2124	2950	200	90 / 68	1084	82	31,6	37	2124	2950	200	91 / 69
1167	70	29,3	37	2242	2950	200	91 / 69	1160	81	33,4	45	2246	2955	225	91 / 69
1240	70	30,9	37	2360	2950	200	92 / 70	1233	80	35,3	45	2364	2955	225	92 / 70
1419	69	34,9	45	2648	2955	225	93 / 71	1410	79	39,7	45	2648	2955	225	94 / 72
1610	68	36,8	45	2955	2955	225	95 / 73	1606	78	44,6	55	2965	2965	250	96 / 74

WPB 2000															
Δ p = 900 mbar							Δ p = 1000 mbar								
m³/h	Δ t (°C)	kW (erf)	kW (M)	min <sup>-1</sup>		IEC (M)	dB(A) (60) / (30)	m³/h	Δ t (°C)	kW (erf)	kW (M)	min <sup>-1</sup>		IEC (M)	dB(A) (60) / (30)
				G	M							G	M		
615	106	23	30	1383	1465	200	88 / 66								
666	103	24,3	30	1465	1465	200	89 / 67	666	115	27,2	37	1465	1465	225	89 / 67
778	99	27,4	37	1635	1465	225	89 / 67	776	110	30,5	37	1641	1465	225	90 / 68
934	95	31,6	37	1896	2950	200	90 / 68	930	107	35,1	45	1900	2955	225	91 / 69
1002	94	33,4	45	2005	2955	225	97 / 69	995	105	37,1	45	2005	2955	225	91 / 69
1079	93	35,5	45	2128	2955	225	91 / 69	1061	104	39,1	45	2111	2955	225	92 / 70
1152	91	37,6	45	2246	2955	225	92 / 70	1144	102	41,7	55	2245	2965	250	93 / 71
1225	90	39,6	45	2364	2955	225	93 / 71	1223	101	44,1	55	2372	2965	250	95 / 72
1406	89	44,7	55	2657	2965	250	94 / 72								

m³/h	Volumenstrom	Capacity	Volume engendré	Portata volumetrica
------	--------------	----------	-----------------	---------------------

Der Volumenstrom bezieht sich auf freie atmosphärische Luft von 1 bar (abs.) und 20° C./ The capacity refers to free atmospheric air at 1 bar (abs.) and 20° C./ Le débit est mesuré à l'atmosphère de 1 bar (abs.) à 20° C./ La portata si riferisce alla pressione atmosferica di 1 bar (ass.) e 20° C.

Tabellenangaben beziehen sich auf betriebswarme Verdichter./ Tables refer to compressor at normal operating temperature./ Les tableaux sont établies, compresseur à température de fonctionnement./ I dati riportati nelle tabelle si riferiscono ai compressori con funzionamento a regime.

Technische Änderungen vorbehalten! / We reserve the right to alter technical information! / Sous réserve de modification technique! / Salvo modifiche tecniche!

WPB 3300															
Δ p = 300 mbar								Δ p = 400 mbar							
m³/h	Δ t (°C)	kW (erf)	kW (M)	min <sup>-1</sup>		IEC (M)	dB(A) (60) / (30)	m³/h	Δ t (°C)	kW (erf)	kW (M)	min <sup>-1</sup>		IEC (M)	dB(A) (60) / (30)
				G	M							G	M		
1334	31	14,9	18,5	1378	1460	180	91 / 69	1312	62	19,6	30	1383	1465	200	92 / 70
1427	30	15,8	18,5	1460	1460	180	94 / 72	1405	60	20,8	30	1465	1465	200	94 / 70
1626	29	18	22	1635	1465	180	95 / 73	1599	59	23	30	1635	1465	200	96 / 74
1923	29	20,9	30	1896	2950	200	96 / 74	1897	59	27,3	37	1896	2950	200	97 / 75
2044	29	22,2	30	2002	2950	200	96 / 74	2017	59	28,9	37	2002	2950	200	97 / 75
2183	29	23,7	30	2124	2950	200	97 / 75	2156	58	30,8	37	2124	2950	200	98 / 76
2317	29	25,2	30	2242	2950	200	97 / 75	2295	58	32,8	45	2246	2955	225	98 / 76
2451	29	26,7	37	2360	2950	200	98 / 76	2429	58	34,7	45	2364	2955	225	99 / 77
2772	29	30,5	37	2643	2950	200	99 / 78	2752	58	39,4	45	2648	2955	225	100 / 78
3126	29	34,8	45	2955	2955	225	100 / 80	3113	58	44,9	55	2965	2965	250	102 / 81
3325	29	37,3	45	3130	2955	225	101 / 81	3312	58	48	55	3141	2965	250	103 / 81

WPB 3300															
Δ p = 500 mbar								Δ p = 600 mbar							
m³/h	Δ t (°C)	kW (erf)	kW (M)	min <sup>-1</sup>		IEC (M)	dB(A) (60) / (30)	m³/h	Δ t (°C)	kW (erf)	kW (M)	min <sup>-1</sup>		IEC (M)	dB(A) (60) / (30)
				G	M							G	M		
1289	53	24,2	30	1383	1465	200	92 / 70	1281	64	29,0	37	1392	1475	225	93 / 71
1383	51	25,7	30	1465	1465	200	95 / 73	1375	61	30,8	37	1475	1475	225	95 / 73
1589	50	29	37	1646	1475	225	96 / 74	1476	60	35	45	1652	1475	225	97 / 75
1879	49	33,7	45	1900	2955	225	97 / 75	1868	59	40,2	55	1906	2965	250	98 / 76
1999	49	35,7	45	2005	2955	225	97 / 75	1988	59	42,6	55	2012	2965	250	98 / 76
2120	48	37,7	45	2128	2955	225	98 / 76	2109	58	45	55	2118	2965	250	99 / 77
2272	48	40,3	55	2253	2965	250	98 / 76	2254	58	47,8	55	2245	2965	250	99 / 77
2417	48	43,8	55	2372	2965	250	99 / 77	2408	57	50,9	75	2380	2975	280	100 / 78
2730	47	48,3	55	2657	2965	250	101 / 79	2722	57	57,3	75	2656	2975	280	101 / 80
3103	47	55	75	2975	2975	280	103 / 82	3086	56	65	75	2975	2975	280	104 / 82
3303	46	58,7	75	3151	2975	280	104 / 82	3286	56	69,4	90	3151	2975	280	105 / 83

WPB 3300															
Δ p = 700 mbar								Δ p = 800 mbar							
m³/h	Δ t (°C)	kW (erf)	kW (M)	min <sup>-1</sup>		IEC (M)	dB(A) (60) / (30))	m³/h	Δ t (°C)	kW (erf)	kW (M)	min <sup>-1</sup>		IEC (M)	dB(A) (60) / (30)
				G	M							G	M		
1265	76	33,7	45	1392	1475	225	93 / 71	1234	87	38,0	45	1377	1475	225	93 / 71
1360	72	35,8	45	1475	1475	225	96 / 74	1352	84	40,9	55	1480	1480	250	96 / 74
1577	70	41	55	1658	1480	250	97 / 75	1557	81	46	55	1665	1480	250	98 / 76
1852	69	46,6	55	1906	2965	250	98 / 76	1820	80	52,6	75	1889	2975	280	98 / 76
1981	69	49,5	75	2019	2975	280	98 / 76	1949	79	55,9	75	2002	2975	280	99 / 77
2102	69	52,3	75	2125	2975	280	99 / 77	2079	79	59,2	75	2116	2975	280	99 / 77
2248	68	55,6	75	2253	2975	280	99 / 77	2208	78	62,5	75	2229	2975	280	100 / 78
2393	68	60	75	2380	2975	280	100 / 78	2358	78	66,5	75	2361	2975	280	101 / 79
2707	67	66,4	75	2656	2975	280	102 / 80	2681	77	75	90	2644	2975	280	102 / 80
3071	67	75,2	90	2975	2975	280	105 / 83								

WPB 3300															
Δ p = 900 mbar															
m³/h	Δ t (°C)	kW (erf)	kW (M)	min <sup>-1</sup>		IEC (M)	dB(A) (60) / (30)	m³/h	Δ t (°C)	kW (erf)	kW (M)	min <sup>-1</sup>		IEC (M)	dB(A) (60) / (30)
				G	M							G	M		
1228	98	42,7	55	1381	1480	250	95 / 73								
1341	95	45,9	55	1480	1480	250	96 / 74								
1553	91	52	75	1671	1485	280	98 / 76								
1809	90	59	75	1889	2975	280	99 / 77								
1938	89	62,6	75	2002	2975	280	100 / 78								
2068	89	66,4	75	2116	2975	280	100 / 78								

Δ p (mbar)	Druckdifferenz	Pressure difference	Pression différentielle	Differenza di pressione
min <sup>-1</sup>	Drehzahl	Speed	Vitesse rotation	Numero giri
G / M	Gebläse / Motor	Blower / Motor	Turbine / Moteur	Soffiante / Motore
Δ t (°C)	Temperaturdifferenz	Temperature difference	Différence de température	Differenza di temperatura
kW (erf)	erforderliche Leistung	Capacity required	Puissance néssaire	Potenza necessaria
kW (M)	Motorleistung	Motor rating	Puissance moteur	Potenza motore
IEC (M)	IEC Motor-Baugröße	IEC Motor size	Série IEC de moteur	Grandezza IEC del motore
dB(A) → DIN 45635	Mittlerer Schalldruckpegel	Average noise level	Niveau sonore moyen	Rumorosità media

WPB 5000															
Δ p = 300 mbar								Δ p = 400 mbar							
m³/h	Δ t (°C)	kW (erf)	kW (M)	min <sup>-1</sup>		IEC (M)	dB(A) (60) / (30)	m³/h	Δ t (°C)	kW (erf)	kW (M)	min <sup>-1</sup>		IEC (M)	dB(A) (60) / (30)
				G	M							G	M		
								<b>1129</b>	48	20	30	770	978	225M-6	72 / 97
<b>1190</b>	35	15	18,5	773	1460	180	71 / 93	<b>1345</b>	46	23	30	869	978	225M-6	72 / 93
<b>1615</b>	32	19	30	978	978	225M-6	72 / 93	<b>1564</b>	44	25	30	978	978	225M-6	73 / 93
<b>1870</b>	32	22	30	1100	978	225M-6	72 / 93	<b>1825</b>	43	29	37	1102	980	250M-6	73 / 93
<b>2150</b>	31	24	30	1236	978	225M-6	72 / 93	<b>2108</b>	42	32	37	1238	980	250M-6	73 / 94
<b>2500</b>	30	28	37	1404	1475	225S-4	73 / 94	<b>2453</b>	41	37	45	1404	1475	225M-4	74 / 96
<b>2648</b>	30	29,5	37	1475	1475	225S-4	73 / 94	<b>2596</b>	41	38	45	1475	1475	225M-4	74 / 96
<b>3029</b>	30	34	45	1659	1475	225M-4	75 / 95	<b>2993</b>	40	44	55	1665	1480	250M-4	76 / 97
<b>3402</b>	30	38	45	1838	2955	225M-4	76 / 97	<b>3372</b>	40	49	75	1848	2970	250M-2	82 / 102
<b>4195</b>	30	47	55	2223	2965	250M-2	79 / 103	<b>4166</b>	40	60	75	2231	2975	280S-2	82 / 105
<b>4790</b>	30	54	75	2509	2970	250M-2	81 / 106	<b>4740</b>	40	69	90	2514	2975	280M-2	84 / 106

WPB 5000															
Δ p = 500 mbar								Δ p = 600 mbar							
m³/h	Δ t (°C)	kW (erf)	kW (M)	min <sup>-1</sup>		IEC (M)	dB(A) (60) / (30)	m³/h	Δ t (°C)	kW (erf)	kW (M)	min <sup>-1</sup>		IEC (M)	dB(A) (60) / (30)
				G	M							G	M		
<b>1091</b>	62	25	30	773	978	225M-6	73 / 93	<b>1054</b>	77	30	37	775	980	250M-6	73 / 95
<b>1295</b>	59	28	37	871	980	250M-6	73 / 94	<b>1262</b>	73	33	45	872	982	280S-6	74 / 96
<b>1525</b>	57	31	37	980	980	250M-6	73 / 95	<b>1487</b>	69	37	45	982	982	280S-6	74 / 96
<b>1775</b>	54	35	45	1101	1475	225M-4	74 / 96	<b>1740</b>	66	42	55	1104	1480	250M-4	75 / 97
<b>2080</b>	53	40	45	1246	1475	225M-4	74 / 96	<b>2054</b>	64	48	55	1250	1480	250M-4	75 / 98
<b>2422</b>	52	45	55	1409	1480	250M-4	75 / 98	<b>2386</b>	62	54	75	1414	1485	280S-4	76 / 99
<b>2567</b>	51	48	55	1480	1480	250M-4	75 / 98	<b>2531</b>	62	57	75	1480	1480	280S-4	76 / 99
<b>2952</b>	50	54	75	1665	1480	280S-4	77 / 99	<b>2937</b>	60	65	75	1675	1480	280S-4	78 / 101
<b>3338</b>	50	61	75	1851	2975	280S-2	78 / 102	<b>3303</b>	60	72	90	1851	2975	280M-2	79 / 102
<b>4122</b>	50	74	90	2231	2975	280M-2	81 / 104	<b>4090</b>	59	79	110	2235	2980	315S-2	82 / 105
<b>4710</b>	49	85	110	2518	2980	315S-2	84 / 107	<b>4685</b>	59	100	132	2518	2980	315M-2	85 / 107

WPB 5000															
Δ p = 700 mbar								Δ p = 800 mbar							
m³/h	Δ t (°C)	kW (erf)	kW (M)	min <sup>-1</sup>		IEC (M)	dB(A) (60) / (30)	m³/h	Δ t (°C)	kW (erf)	kW (M)	min <sup>-1</sup>		IEC (M)	dB(A) (60) / (30)
				G	M							G	M		
<b>1020</b>	93	34	45	775	980	280S-6	73 / 95	<b>991</b>	109	39,0	45	775	980	280S-6	73 / 95
<b>1224</b>	87	39	45	871	980	280S-6	74 / 96	<b>1200</b>	101	44	55	874	984	280M-6	74 / 96
<b>1462</b>	82	43	55	984	984	280M-6	75 / 97	<b>1442</b>	95	50	75	988	988	315S-6	75 / 98
<b>1714</b>	79	49	55	1104	1480	250M-4	76 / 99	<b>1694</b>	91	56	75	1108	1485	280S-4	76 / 99
<b>2030</b>	76	56	75	1254	1485	280S-4	76 / 101	<b>2003</b>	87	63	75	1254	1485	280S-4	77 / 100
<b>2363</b>	73	63	75	1414	1485	280S-4	77 / 101	<b>2335</b>	85	71	90	1414	1485	280M-4	77 / 101
<b>2510</b>	73	66	75	1485	1485	280S-4	77 / 102	<b>2483</b>	84	75	90	1485	1485	280M-4	77 / 101
<b>2917</b>	71	75	90	1681	1485	280M-4	79 / 102	<b>2890</b>	82	86	110	1681	1485	315S-4	79 / 103
<b>3280</b>	70	83	110	1858	2980	315S-2	80 / 103	<b>3260</b>	82	95	110	1858	2980	315S-2	81 / 104
<b>4070</b>	68	102	132	2235	2980	315M-2	83 / 106	<b>4045</b>	78	115	132	2235	2980	315M-2	83 / 107
<b>4655</b>	68	116	132	2518	2980	315M-2	86 / 107	<b>4630</b>	78	132	160	2518	2980	315L-2	86 / 108

WPB 5000															
Δ p = 900 mbar								Δ p = 1000 mbar							
m³/h	Δ t (°C)	kW (erf)	kW (M)	min <sup>-1</sup>		IEC (M)	dB(A) (60) / (30)	m³/h	Δ t (°C)	kW (erf)	kW (M)	min <sup>-1</sup>		IEC (M)	dB(A) (60) / (30)
				G	M							G	M		
<b>1177</b>	116	50	75	874	1485	280S-4	75 / 97								
<b>1410</b>	109	56	75	983	1485	280S-4	75 / 98								
<b>1670</b>	104	63	75	1108	1485	280S-4	77 / 99	<b>1650</b>	116,3	69	90	1110	1480	280M-4	77 / 100
<b>1978</b>	99	71	90	1254	1485	280M-4	77 / 100	<b>1925</b>	111	77,5	90	1239	1480	280M-4	78 / 101
<b>2310</b>	96	80	90	1414	1485	280M-4	78 / 101	<b>2260</b>	107,5	89	110	1405	1485	315S-4	78 / 102
<b>2460</b>	95	84	110	1485	1485	315S-4	78 / 102	<b>2437</b>	106	93	110	1485	1485	315S-4	79 / 103
<b>2850</b>	92	95	110	1673	1485	315S-4	79 / 103	<b>2830</b>	103	106	132	1673	1485	315M-4	81 / 103
<b>3235</b>	90	106	132	1858	2980	315M-2	81 / 104	<b>3210</b>	101	118	132	1856	1485	315M-4	84 / 107
<b>4020</b>	88	130	160	2235	2980	315L-2	84 / 106	<b>3730</b>	99	135	160	2103	2980	315L-2	85 / 109

m³/h	Volumenstrom	Capacity	Volume engendré	Portata volumetrica
------	--------------	----------	-----------------	---------------------

Der Volumenstrom bezieht sich auf freie atmosphärische Luft von 1 bar (abs.) und 20° C./ The capacity refers to free atmospheric air at 1 bar (abs.) and 20° C./ Le débit est mesuré à l'atmosphère de 1 bar (abs.) à 20° C./ La portata si riferisce alla pressione atmosferica di 1 bar (ass.) e 20° C.

Tabellenangaben beziehen sich auf betriebswarme Verdichter./ Tables refer to compressor at normal operating temperature./ Les tableaux sont établies, compresseur à température de fonctionnement./ I dati riportati nelle tabelle si riferiscono ai compressori con funzionamento a regime.

Technische Änderungen vorbehalten! / We reserve the right to alter technical information! / Sous réserve de modification technique! / Salvo modifiche tecniche!

WPB 6500															
Δ p = 300 mbar							Δ p = 400 mbar								
m³/h	Δ t (°C)	kW (erf)	kW (M)	min <sup>-1</sup>		IEC (M)	dB(A) (60) / (30)	m³/h	Δ t (°C)	kW (erf)	kW (M)	min <sup>-1</sup>		IEC (M)	dB(A) (60) / (30)
				G	M							G	M		
2412	32	27,5	37	930	980	250	71 / 93	2353	43	36,1	45	932	982	280	72 / 93
2569	32	29	37	980	980	250	72 / 93	2505	43	38	45	980	980	280	73 / 94
2932	31	32,5	45	1095	982	280	73 / 94	2868	42	42,7	55	1095	982	280	74 / 95
3435	31	37,7	45	1255	1475	225	74 / 95	3388	41	49,3	75	1260	1480	280	75 / 96
3892	30	42,2	55	1400	1475	250	75 / 96	3851	40	55,4	75	1407	1480	280	75 / 97
4128	30	44,7	55	1475	1475	250	75 / 96	4081	40	58,5	75	1480	1480	280	76 / 98
4659	29	50,1	75	1644	1480	280	76 / 97	4597	49	65,4	75	1644	1480	280	76 / 98
4964	29	53,4	75	1741	1480	280	76 / 98	4902	49	69,6	90	1741	1480	280	77 / 98
5306	29	57,1	75	1850	1480	280	77 / 98	5245	49	74,4	90	1850	1480	280	78 / 99

WPB 6500															
Δ p = 500 mbar							Δ p = 600 mbar								
m³/h	Δ t (°C)	kW (erf)	kW (M)	min <sup>-1</sup>		IEC (M)	dB(A) (60) / (30)	m³/h	Δ t (°C)	kW (erf)	kW (M)	min <sup>-1</sup>		IEC (M)	dB(A) (60) / (30)
				G	M							G	M		
2298	55	44,8	55	932	982	280	73 / 95	2260	67	53,6	75	935	985	315	74 / 96
2456	54	47,3	55	982	982	280	73 / 96	2418	66	56,5	75	985	985	315	75 / 97
2814	53	52,8	75	1095	985	315	74 / 97	2767	64	63	75	1095	985	315	75 / 98
3335	51	61,2	75	1260	1480	315	74 / 97	3289	62	73	90	1260	1480	315	76 / 99
3798	51	68,7	90	1407	1480	315	75 / 98	3766	61	81,8	110	1411	1485	315	76 / 99
4029	50	72,5	90	1480	1480	315	75 / 99	3999	61	86,4	110	1485	1485	315	76 / 100
4605	50	81,7	110	1663	1485	315	76 / 99	4560	60	97	110	1663	1485	315	77 / 101
4885	49	86,4	110	1752	1485	315	76 / 99	4841	59	102,8	132	1752	1485	315	77 / 102
5184	49	91,6	110	1847	1485	315	77 / 100	5140	59	109	132	1847	1485	315	78 / 103

WPB 6500															
Δ p = 700 mbar							Δ p = 800 mbar								
m³/h	Δ t (°C)	kW (erf)	kW (M)	min <sup>-1</sup>		IEC (M)	dB(A) (60) / (30)	m³/h	Δ t (°C)	kW (erf)	kW (M)	min <sup>-1</sup>		IEC (M)	dB(A) (60) / (30)
				G	M							G	M		
2218	80	62,3	75	935	985	315	75 / 98	2181	92	71,0	90	935	985	315	76 / 99
2377	78	65,7	75	985	985	315	75 / 99	2340	91	74,9	90	985	985	315	77 / 100
2726	76	73,2	90	1095	985	315	76 / 100	2690	88	83,4	110	1095	985	315	77 / 101
3258	73	84,7	110	1263	1485	315	77 / 101	3222	84	96,5	110	1263	1485	315	78 / 102
3726	72	95	110	1411	1485	315	78 / 102	3691	83	108,2	132	1411	1485	315	78 / 103
3960	71	100,2	132	1485	1485	315	79 / 103	3925	82	114,2	132	1485	1485	315	79 / 104
4521	70	113	132	1663	1485	315	80 / 104	4487	80	128,5	160	1663	1485	315	80 / 104
4802	69	119,3	132	1752	1485	315	81 / 105	4768	80	135,8	160	1752	1485	315	81 / 105
5101	69	126,4	160	1847	1485	315	82 / 105	5067	79	143,9	160	1847	1485	315	83 / 106

WPB 6500															
Δ p = 900 mbar							Δ p = 1000 mbar								
m³/h	Δ t (°C)	kW (erf)	kW (M)	min <sup>-1</sup>		IEC (M)	dB(A) (60) / (30)	m³/h	Δ t (°C)	kW (erf)	kW (M)	min <sup>-1</sup>		IEC (M)	dB(A) (60) / (30)
				G	M							G	M		
2149	105	79,7	90	935	985	315	76 / 99	2121	118	88,7	110	935	985	315	77 / 100
2308	103	84	110	985	985	315	77 / 100	2280	116	93,2	110	985	985	315	77 / 100
2658	100	93,6	110	1095	985	315	77 / 101	2630	112	104	132	1095	985	315	77 / 100
3191	96	108,3	132	1263	1485	315	78 / 102	3164	107	120,1	160	1263	1485	315	77 / 101
3660	93	121,5	160	1411	1485	315	80 / 103	3632	104	134,7	160	1411	1485	315	78 / 102
3894	92	128,1	160	1485	1485	315	81 / 104	3867	103	142	160	1485	1485	315	80 / 103
4456	91	144,4	160	1663	1485	315	82 / 105	4439	101	160	200	1666	1488	315	82 / 105
4737	90	152,2	200	1752	1488	315	82 / 105	4710	100	169,1	200	1752	1488	315	82 / 106
5046	89	161,4	200	1850	1488	315	83 / 106	5020	99	180	200	1850	1488	315	82 / 106

Δ p (mbar)	Druckdifferenz	Pressure difference	Pression différentielle	Differenza di pressione
min <sup>-1</sup>	Drehzahl	Speed	Vitesse rotation	Numero giri
G / M	Gebälse / Motor	Blower / Motor	Turbine / Moteur	Soffiante / Motore
Δ t (°C)	Temperaturdifferenz	Temperature difference	Différence de température	Differenza di temperatura
kW (erf)	erforderliche Leistung	Capacity required	Puissance néssaire	Potenza necessaria
kW (M)	Motorleistung	Motor rating	Puissance moteur	Potenza motore
IEC (M)	IEC Motor-Baugröße	IEC Motor size	Série IEC de moteur	Grandezza IEC del motore
dB(A) → DIN 45635	Mittlerer Schalldruckpegel	Average noise level	Niveau sonore moyen	Rumorosità media

WPB 8300															
Δ p = 300 mbar								Δ p = 400 mbar							
m³/h	Δ t (°C)	kW (erf)	kW (M)	min <sup>-1</sup>		IEC (M)	dB(A) (60) / (30)	m³/h	Δ t (°C)	kW (erf)	kW (M)	min <sup>-1</sup>		IEC (M)	dB(A) (60) / (30)
				G	M							G	M		
3704	32	42,0	55	922	984	283	73 / 94	3636	42	55,2	75	926	988	310	74 / 94
4001	31	45,0	55	984	984	283	73 / 94	3934	41	59,1	75	988	988	310	74 / 95
4619	31	51,3	75	1113	988	310	74 / 95	4534	41	67	90	1113	988	313	75 / 96
5241	30	58,0	75	1243	1485	280	75 / 96	5157	40	75,4	90	1243	1485	283	76 / 98
5953	30	65,8	75	1392	1485	280	76 / 98	5875	40	85,4	110	1393	1486	310	77 / 98
6398	30	70,8	90	1485	1485	283	77 / 98	6320	40	91,8	110	1486	1486	310	78 / 99
7343	30	82	110	1683	1485	310	79 / 99	7267	40	105,7	132	1684	1486	313	79 / 100
7815	30	87,8	110	1782	1485	310	79 / 100	7740	40	112,9	132	1783	1486	313	80 / 101
8292	31	93,8	110	1882	1485	310	80 / 101	8218	40	120,4	160	1883	1486	316	81 / 102

WPB 8300															
Δ p = 500 mbar								Δ p = 600 mbar							
m³/h	Δ t (°C)	kW (erf)	kW (M)	min <sup>-1</sup>		IEC (M)	dB(A) (60) / (30)	m³/h	Δ t (°C)	kW (erf)	kW (M)	min <sup>-1</sup>		IEC (M)	dB(A) (60) / (30)
				G	M							G	M		
3563	53	68,3	90	926	988	313	75 / 96	3501	64	81,3	90	926	988	313	76 / 98
3862	52	73,0	90	988	988	313	75 / 97	3800	63	87,0	110	988	988	316	76 / 99
4462	51	82,7	110	1113	988	316	76 / 98	4401	62	98,4	110	1113	988	316	77 / 100
5096	50	93,1	110	1245	1486	310	77 / 99	5036	61	110,7	132	1245	1486	313	78 / 101
5806	50	105,1	132	1393	1486	313	78 / 100	5746	60	124,8	160	1393	1486	316	79 / 102
6251	49	112,7	132	1486	1486	313	79 / 101	6193	59	133,8	160	1486	1486	316	80 / 103
7200	49	130	160	1684	1486	316	80 / 102	7151	59	153,6	200	1686	1488	317	81 / 104
7673	49	138,1	160	1783	1486	316	81 / 103	7630	59	163,7	200	1786	1488	317	82 / 105
8166	49	147,3	200	1886	1488	317	82 / 104	8109	59	174,1	200	1886	1488	317	83 / 106

WPB 8300															
Δ p = 700 mbar								Δ p = 800 mbar							
m³/h	Δ t (°C)	kW (erf)	kW (M)	min <sup>-1</sup>		IEC (M)	dB(A) (60) / (30)	m³/h	Δ t (°C)	kW (erf)	kW (M)	min <sup>-1</sup>		IEC (M)	dB(A) (60) / (30)
				G	M							G	M		
3510	76	95,8	110	939	988	316	77 / 100	3454	87	108,8	132	937	986	317	77 / 100
3737	75	100,7	132	986	986	317	77 / 100	3690	86	114,7	132	986	986	317	77 / 100
4267	73	112,4	132	1096	986	317	78 / 101	4231	84	128,1	160	1098	988	318	78 / 101
5070	71	130,3	160	1263	1486	316	79 / 103	5035	81	148,5	200	1265	1488	317	79 / 103
5786	70	146,6	200	1412	1486	317	80 / 104	5761	80	166,9	200	1414	1488	317	81 / 104
6151	69	155,1	200	1488	1488	317	81 / 104	6107	79	176,3	200	1488	1488	317	81 / 104
7010	69	175,4	200	1667	1488	317	82 / 106	6966	78	199,2	250	1667	1488	315	82 / 106
7427	68	185,4	250	1754	1488	315	83 / 106	7383	78	210,5	250	1754	1488	315	83 / 107
7897	68	197,0	250	1852	1488	315	84 / 108								

WPB 8300															
Δ p = 900 mbar															
m³/h	Δ t (°C)	kW (erf)	kW (M)	min <sup>-1</sup>		IEC (M)	dB(A) (60) / (30)	m³/h	Δ t (°C)	kW (erf)	kW (M)	min <sup>-1</sup>		IEC (M)	dB(A) (60) / (30)
				G	M							G	M		
3423	99	122,3	160	939	988	318	77 / 101								
3660	98	128,9	160	988	988	318	78 / 101								
4191	95	143,7	160	1098	988	318	78 / 102								

m³/h	Volumenstrom	Capacity	Volume engendré	Portata volumetrica
------	--------------	----------	-----------------	---------------------

Der Volumenstrom bezieht sich auf freie atmosphärische Luft von 1 bar (abs.) und 20° C./ The capacity refers to free atmospheric air at 1 bar (abs.) and 20° C./ Le débit est mesuré à l'atmosphère de 1 bar (abs.) à 20° C./ La portata si riferisce alla pressione atmosferica di 1 bar (ass.) e 20° C.

Tabellenangaben beziehen sich auf betriebswarme Verdichter./ Tables refer to compressor at normal operating temperature./ Les tableaux sont établies, compresseur à température de fonctionnement./ I dati riportati nelle tabelle si riferiscono ai compressori con funzionamento a regime.

Technische Änderungen vorbehalten! / We reserve the right to alter technical information! / Sous réserve de modification technique! / Salvo modifiche tecniche!