

RER 26020 → RER 62050

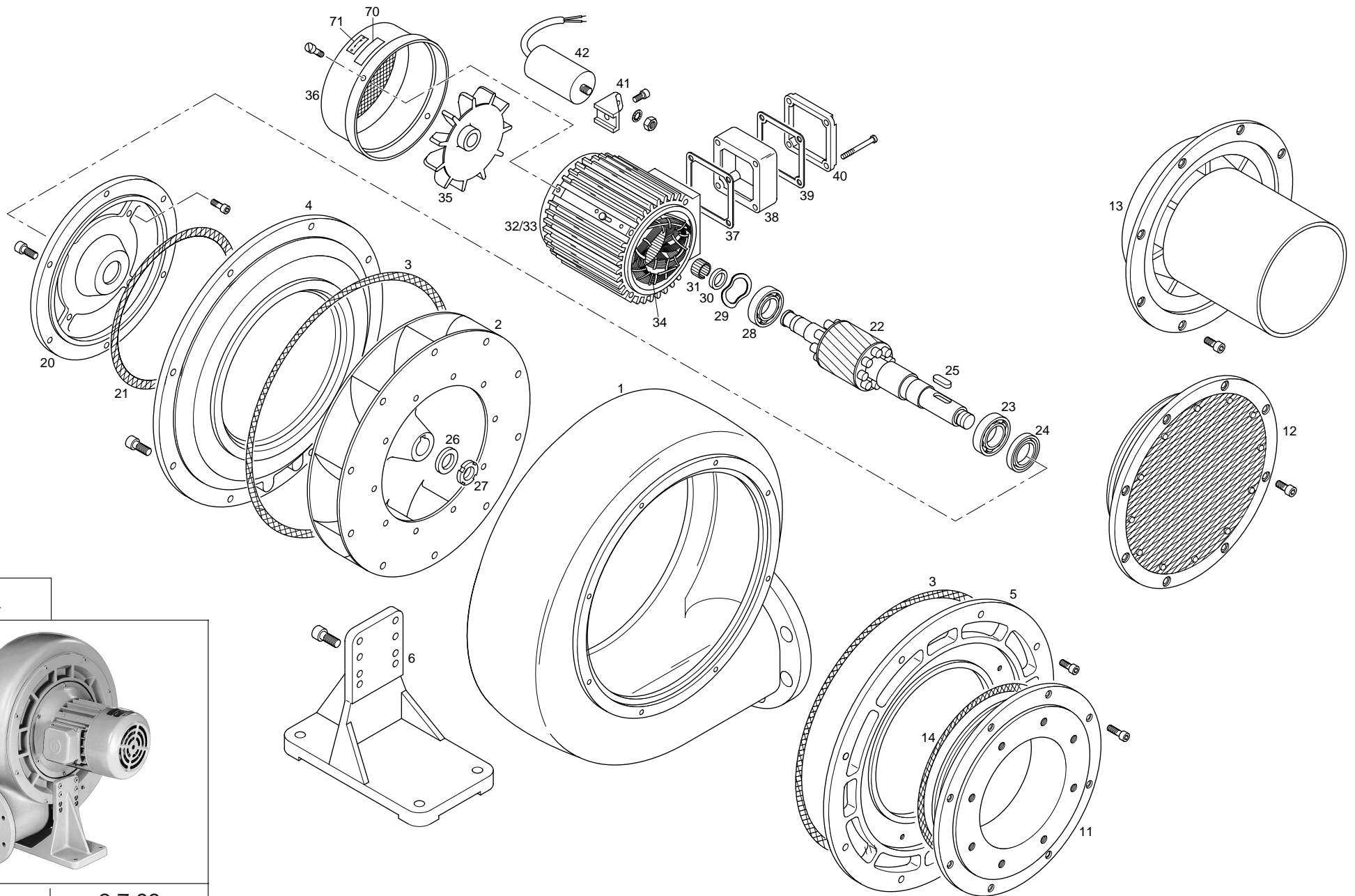

RER

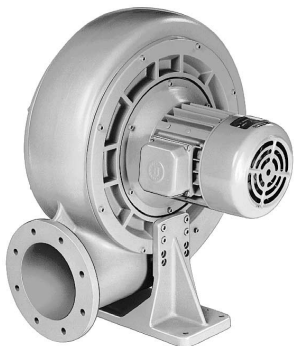

E 750

2.7.93

	Verdichterteile	Compressor part	Eléments compresseur	Parti di compressore						
1	Spiralgehäuse	Spiral housing	Carter centrifuge	Corpo centrifico	28	V	Rillenkugellager	Deep groove ball bearing	Roulement aiguille	Cuscinetto a sfera
2	Laufrad	Impellor	Roue à aube	Girante	29		Distanzscheibe	Spacer shim	Rondelle entretoise	Disco distanziatore
3	Schnur	Sealing cord	Cordon	Cordone in gomma	30	D	INA-Dichtring	INA-seal ring	Joint d'arbre INA	Anello di tenuta INA
4	Zentrierdeckel (motorseitig)	Centering cover (motorside)	Couvercle de centrage (côté moteur)	Coperchio di centraggio (lato motore)	31	V	Toleranzring	Tolerance ring	Entretoise	Anello di tolleranza
5	Zentrierdeckel (saugseitig)	Centering cover (suction side)	Couvercle de centrage (côté aspiration)	Coperchio di centraggio (lato aspirazione)	32		Motorgehäuse komplett	Motor housing complete	Enveloppe et stator	Carcassa motore completa
					33		Motorgehäuse (Einzelteil)	Motor housing (single part)	Enveloppe stator	Carcassa motore (singola)
					34		Stator	Stator	Stator	Statore
					35		Ventilator	Fan	Ventilateur	Ventilatore
	Anschlußteile (saugseitig)	Connection pieces (suction side)	Eléments raccordement (côté aspiration)	Parti di collegamento (lato aspirazione)	36		Schutzhaube	Protection cover	Capot protection	Calotta di protezione
11	Anschlußflansch	Connection flange	Bride raccordement	Flangia di collegamento	37	D	Dichtring	Sealing ring	Anneau d'étanchéité	Anello guarnizione
12	Siebflansch	Mesh flange	Bride crépine	Flangia a reticella	38		Klemmenkasten	Terminal box	Boîte à bornes	Morsettiera
13	Rohrstutzen	Pipe socket	Embout	Tronchetto	39	D	Dichtung	Gasket	Joint	Guarnizione
14	Schnur	Sealing cord	Cordon	Cordone in gomma	40		Klemmkasten-Deckel	Terminal box cover	Couvercle boîte de bornes	Coperchio morsettiera
					41		Konsole (1~)	Console (1~)	Console (1~)	Mensola (1~)
	Antrieb	Drive	Entraînement	Azionamento	42		Kondensator (1~)	Capacitor (1~)	Condensateur (1~)	Condensatore (1~)
20	Motorflansch	Motor flange	Bride moteur	Flangia motore						
21	Schnur	Sealing cord	Cordon	Cordone in gomma			Schilder	Labels	Plaques signalétiques	Targhette
22	Motorwelle mit Rotor	Motor shaft with rotor	Arbre moteur avec rotor	Albero motore con rotore	70		Datenschild	Data plate	Etiquette caractéristique	Targhetta dati
23	V Rillenkugellager	Deep groove ball bearing	Roulement aiguille	Cuscinetto a sfera	71		Pfeilschild	Direction arrow	Sens de rotation	Freccia senso di rotazione
24	V Wellendichtring	Shaft seal	Joint d'arbre	Anello di tenuta sull' albero						
25	Paßfeder	Key	Clavette	Chiavetta						
26	Federscheibe	Spring shim	Rondelle ressort	Disco a molla						
27	Wellenmutter	Shaft nut	Ecrou d'arbre	Ghiera						

Bei Bestellungen folgendes angeben: Typ, Fabrikations-Nr., Positions-Nr., Motor (kW, V, Hz)
To order please indicate: model, serial-no., item-no., motor (kW, V, Hz)
En cas de commande préciser: type d'appareil, no. de position des pièces, moteur (kW, V, Hz)
Nell'ordine indicare: tipo, numero di matricola, numero di posizione dei ricambi, motore (kW, V, Hz)

V = Verschleißteile
V = Wearing parts
V = Pièces d'usure
V = Parti usurabili

D = Dichtungen
D = Seals
D = Joints
D = Guarnizioni

Werner Rietschle GmbH + Co. KG
 Postfach 1260 • D-79642 Schopfheim
 ☎ 07622 / 392-0 • Fax 07622 / 392300
 e-mail: info@rietschle.com