

Operating instructions L-BL2



**2BL2041
2BL2061
2BL2101
2BL2141
2BL2251
2BL2281
2BL2341**



**L-Serie
L-Series**

**Flüssig-
keitsring
Liquid Ring**



Contents

System design	3
1 Safety	4
1.1 Definitions	4
1.1.1 Safety alert symbol	4
1.1.2 Signal words	4
1.2 General safety precautions	4
1.3 Residual risks	6
2 Intended Use	7
3 Technical Data	8
3.1 Mechanical data	8
3.1.1 Weight	8
3.1.2 Filling capacity for operating liquid	8
3.1.3 Filling capacity for antiliming agent	8
3.1.4 Filling quantity for anti-corrosive agent for longer shut-down	8
3.1.5 Minimum distances for heat dissipation	8
3.1.6 Spacing of securing eyes	9
3.1.7 Noise level	9
3.1.8 Operating speed	9
3.1.9 Tightening torques	9
3.2 Electrical data	10
3.3 Operating conditions	10
3.3.1 Default conditions	10
3.3.2 Temperatures	10
3.3.3 Pressures	10
4 Transport and Handling	11
5 Installation	12
5.1 Installation	12
5.2 Electrical connection (motor)	14
5.3 Filling	16
5.4 Connection of pipes/hoses	18
5.4.1 Inlet connection	18
5.4.2 Exhaust-air connection	19
5.5 Accessories	19
6 Commissioning	20
6.1 Preparation and start-up	20
6.2 Shut-down	20
7 Operation	21
7.1 Start-up and shut-down	21
7.2 Operation within the process	21
7.2.1 Loss of operating liquid	21
7.2.2 Increase in operating liquid	22
8 Shutting Down and Longer Standstill	23
8.1 Draining	23
8.2 Preparing for longer shut-down	23
8.3 Storage conditions	24
9 Servicing	25
9.1 Maintenance	26
9.2 Repairs/troubleshooting	28
9.3 Service/After-sales service	30
9.4 Decontamination and Declaration of Clearance	30
10 Disposal	31
EU declaration of conformity	32
Form for statement on safety	33

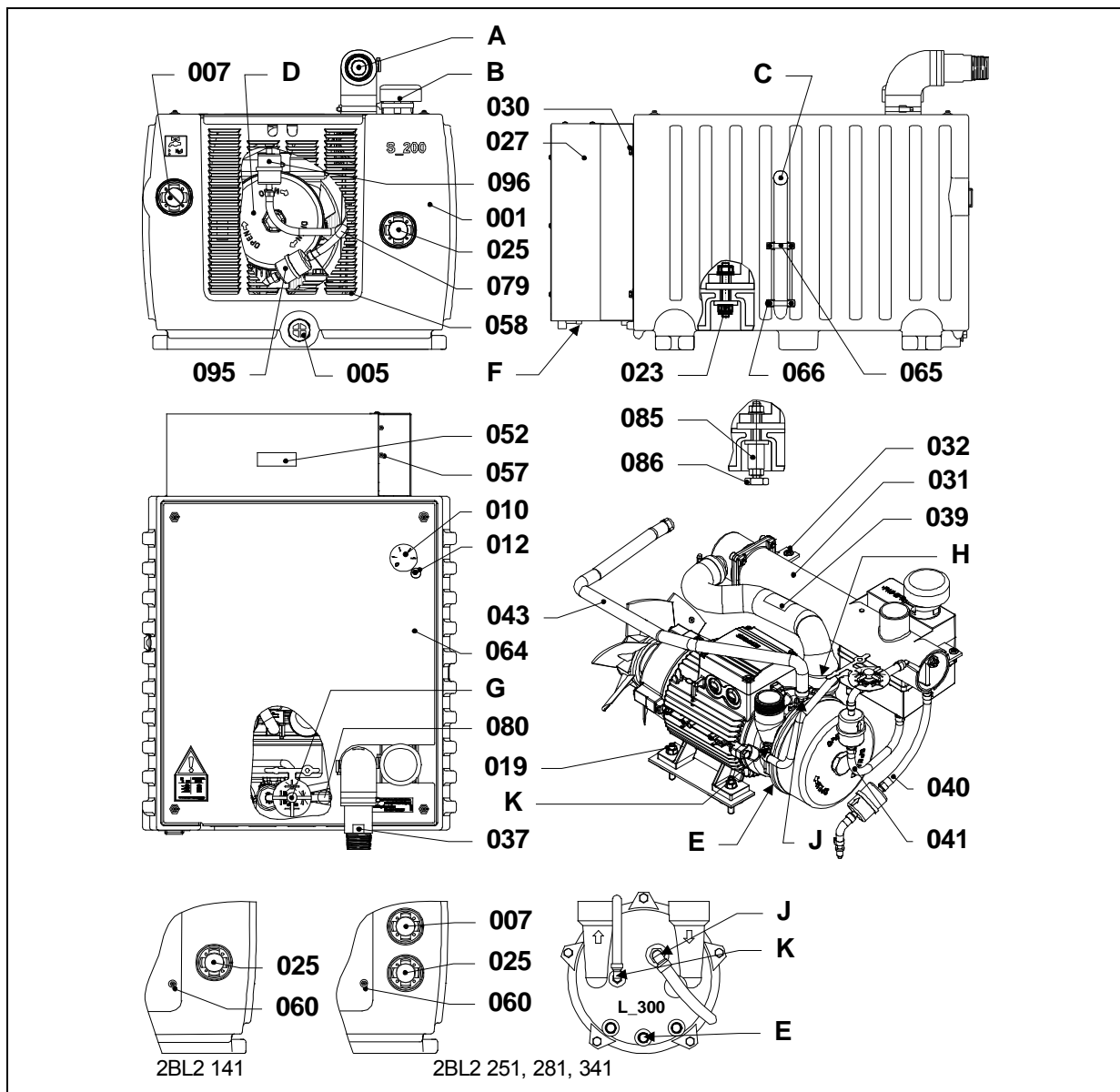

Fig. 1: System design

A	Inlet connection	027	Water or air water cooler
B	Exhaust-air connection	030	Screw
C	Cable inlet	031	Condensation cooler
D	Installed unit (L-BV7 pump)	032	Screw
E	Draining installed unit	037	Connecting piece
F	Draining cooler	039	Intake hose with check valve
G	3-way valve (only 2BL2 041 to 2BL2 141)	040	Injection water pipe
H	Screw-in connecting sleeve	041	Condensate pipe
J	Operating liquid hole	043	Operating liquid pipe
K	Cavitation protection hole	052	Rating plate
		057	Screw
		058	Protective screen
001	U-separator	060	Screw
005	Drain opening	064	Cover plate
007	Filling opening and connection for drain controller	065	Cord grip
010	Fill level indicator	066	Screw
012	Screw	079	Restrictor sleeve for water pipe
019	Nut	080	Restrictor sleeve for air pipe
023	Nut	095	Filter
025	Connection for supply or drain controller	096	Filter

1 Safety

1.1 Definitions

To point out dangers and important information, the following signal words and symbols are used in these operating instructions:

1.1.1 Safety alert symbol

The **safety alert symbol**  is located in the safety precautions in the highlighted heading field on the left next to the signal word (DANGER, WARNING, CAUTION).

Safety precautions **with** a safety alert symbol indicate a danger of **injuries**.

Be sure to follow these safety precautions to protect against **injuries or death!**

Safety precautions **without** a safety alert symbol indicate a danger of **damage**.

1.1.2 Signal words

- DANGER** The **signal words** are located in the safety precautions in the highlighted heading field.
- WARNING** They follow a certain hierarchy and indicate (in conjunction with the safety alert symbol, see Chapter 1.1.1) the **seriousness of the danger** and the **type of warning**.
- CAUTION**
- NOTICE**
- NOTE** See the following explanations:

 DANGER
<p>Danger of injuries. Indicates an imminently hazardous situation, that will result in death or serious injury if the corresponding measures are not taken.</p>

 WARNING
<p>Danger of injuries. Indicates a potentially hazardous situation, that could result in death or serious injury if the corresponding measures are not taken.</p>

 CAUTION
<p>Danger of injuries. Indicates a potentially hazardous situation, that may result in minor or moderate injury if the corresponding measures are not taken.</p>

CAUTION
<p>Danger of damage. Indicates a potentially hazardous situation that may result in property damage if the corresponding measures are not taken.</p>

NOTICE
<p>Indicates a possible disadvantage, i.e. undesirable conditions or consequences can occur if the corresponding measures are not taken.</p>

NOTE
<p>Indicates a possible advantage if the corresponding measures are taken; tip.</p>

1.2 General safety precautions

 WARNING
<p>Improper use of the system can result in serious or even fatal injuries! These operating instructions</p> <ul style="list-style-type: none"> must have been completely read and understood before the start of any work with or on the system, must be strictly observed, must be available at the system operating location.

 WARNING
<p>Improper use of the system can result in serious or even fatal injuries! Only operate the system</p> <ul style="list-style-type: none"> for the purposes indicated under "Intended Use"! with fluids specified under "Proper use"! with the values indicated under "Technical Data"!

 WARNING
<p>Improper use of the system can result in serious or even fatal injuries! All work on and with the system (transport, installation, commissioning, shut-down, maintenance, disposal) may only be carried out by trained, reliable personnel!</p>

⚠ WARNING

When working on the system, there is danger of injury, e.g. due to cutting/cutting off, crushing and burns!

During all work on and with the system (transport, installation, operation, shut-down, maintenance, disposal) wear **personal safety equipment (safety helmet, protective gloves, safety shoes)!**

⚠ WARNING

Hair and clothing can be pulled into the system or caught and wound up by moving parts!

Do not wear long, loose hair or loose-fitting clothes!

Use a hair net!

⚠ DANGER

Electrical danger!

Before beginning work on the system, the following measures must be carried out:

- Deenergise.
- Secure against being switched on again.
- Determine whether deenergised.
- Ground and short-circuit.
- Cover or block off adjacent energised parts.

⚠ DANGER

Electrical danger!

Work on electrical installations may be carried out by trained and authorised electricians only!

⚠ DANGER

Electrical danger!

Do not open the motor terminal box unless absence of electricity has been ensured!

⚠ WARNING

Danger from vacuum!

Danger due to escaping fluid!

Relieve pressure or vacuum before beginning to work on the system!

Make sure that pipes/hoses and vessels to be opened have been relieved of pressure or vacuum and that no fluids might leak out before loosening any connectors and fasteners.

⚠ WARNING

Danger from vacuum!

Danger due to escaping fluid!

Carry out the following tasks prior to commissioning, after every disassembly and reassembly and at regular intervals:

- Check pipe/hose connections, pipes/hoses and vessels for sufficient strength, tightness and secure fixing!
- Check fasteners for secure seating!

⚠ WARNING

Danger from vacuum!

Do not operate the unit unless the pipe / hose has been fitted to the inlet connection!

In particular, do not look into the inlet connection or move your eyes in front of the inlet connection opening if the system might start up and generate a vacuum!

⚠ WARNING

Danger due to rotating parts!

Only operate the system when fully assembled:

- with hoses connected to inlet and discharge connection as well as to operating liquid connection of installed unit
- with the pipes/hoses and fasteners of the operating-liquid circuit mounted
- with cover plate and water cooler of separator mounted.

Do not disassemble unless the system has been shut down and come to a complete standstill!

Consider that the system has a certain run-out!

⚠ WARNING

Danger due to rotating parts!

Do not reach into the installed unit through opened intake or discharge connection!

Do not insert objects into the installed unit through the openings!

⚠ WARNING

Danger of burns/scalding from hot fluids and hot surfaces of the installed unit!

Allow to cool after shut-down!

CAUTION

Danger from excessive pressure!
Danger from system clogging!
 Dirt can enter the system through the exhaust-air connection! Clogging is possible!
 Do not remove the protective cap from the discharge connection!

NOTICE

The pumped gases/vapours are expelled into the surrounding area via the exhaust-air connection. They are not directed through a pipe or a hose.
 If delivery-side piping is desired:
 Enquiry with Service is **absolutely necessary!**

⚠ WARNING

Danger from caustic or toxic fluids!
 In case of corrosive or toxic fluids (operating liquid, pumped gases/vapours):
 Enquiry with Service is **absolutely necessary!**
 Wear appropriate personal protective equipment (protective gloves, safety goggles, respiratory protection) when working on or near the system.
 If appropriate, attach appropriate warning sign(s) to the system, e.g. 'Warning! Corrosive materials!', 'Warning! Harmful or irritant material!' or 'Warning! Toxic material!'.

NOTE

For the system design, see Fig. 1, Pg. 3. The item numbers (Item) specified in the text refer to this illustration.

1.3 Residual risks

⚠ WARNING

Danger zone:
 Not surfaces of installed unit.
Hazard:
 Burns/scalding possible.
Protective measures:
 Attach warning sign "Warning! Hot surface!" .

⚠ WARNING

Danger zone:
 External fan of installed unit.
Hazard:
 Long, open hair may be drawn into the external fan of the installed unit with the cover plate and protective screen of the system removed!
Protective measures:
 Wear hair net!

2 Intended Use

These operating instructions

- apply to vacuum pumps of the L-BL2 series, models 2BL2 041, 2BL2 061, 2BL2 101, 2BL2 141, 2BL2 251, 2BL2 281 and 2BL2 341
- contain instructions bearing on transport and handling, installation, commissioning, operation, shut-down, storage, servicing and disposal of the L-BL2,
- must be completely read and understood by all operating and servicing personnel before beginning to work with or on the L-BL2,
- must be strictly observed,
- must be available at the site of operation of the L-BL2.

About the operating and servicing personnel of the L-BL2:

- These persons must be trained and authorised for the work to be carried out.
- Work on electrical installations may be carried out by trained and authorised electricians only.

The L-BL2s

- are systems for generating a vacuum.
- contain a liquid-ring vacuum pump of the L-BV7 series, model 2BV7 or L-BV5, model 2BV5 (in the following referred to as "unit"), which is installed in a liquid separator (in the following referred to as "separator").
- are used to extract, transport and compress the following **pumped gases/vapours**:
 - all dry and moist gases, which are not explosive, aggressive or toxic,
 - preferably air or air/vapor mixtures.
 - For gases/vapours that differ, an enquiry must be made with the Service Department.
- are designed for operation with the following **operating liquids**:
 - with a pH of 6 to 9, which is free of solid materials (such as sand),
 - usually normal tap water.
 - If the pH values or operating liquids differ, it is necessary to contact the Service Department.
- release gases with the following properties into the environment during operation:
 - discharge temperature \approx ambient temperature,
 - discharge pressure \approx ambient pressure,
 - absolutely clean and dust-free.

- exist in the following designs:
 - 2BL2 041
 - 2BL2 061
 - 2BL2 101
 - 2BL2 141
 - 2BL2 251
 - 2BL2 281
 - 2BL2 341
- are oil-free and non-contacting units.
- are air-cooled units.
- are intended for industrial applications.
- are designed for continuous operation.

When operating the L-BL2, the limits listed in Chapter 3, "Technical Data", Pg. 8 ff. must always be complied with.

Foreseeable Misuse

It is prohibited

- to use the L-BL2 in non-industrial applications, unless the necessary protection is provided on the system, e.g. guards suitable for children's fingers,
- to use the device in rooms in which explosive gases can occur if the S₂₀₀ is not expressly intended for this purpose,
- to extract, to deliver and to compress explosive, flammable, corrosive or toxic fluids, unless the S₂₀₀ is specifically designed for this purpose,
- to operate the L-BL2 with values other than those specified in Chapter 3, "Technical Data", Pg. 8 ff,
- the continuous operation with anti-corrosive agent or antiliming agent.

Any unauthorised modifications of the L-BL2 are prohibited for safety reasons.

Maintenance and repair work by the operator are only permitted in the scope described in these operating instructions.

Any maintenance and repair work going beyond this may only be conducted by companies authorised by the manufacturer (enquiry with the Service Department necessary).

This especially applies to the unit installed in the L-BL2 (liquid-ring vacuum pump of the L-BV7 series, model 2BV7 or L-BV5, model 2BV5): The installed unit may be neither removed nor dismantled! any maintenance and repair work, such as replacing worn or defective components, may only be carried out by companies authorised by the manufacturer (please contact the Service Department).

3 Technical Data

3.1 Mechanical data

3.1.1 Weight

Type	Weight when not filled with water	
	approx. [kg]	approx. [lbs]
2BL2 041	38	83.8
2BL2 061	55	121
2BL2 101	68	150
2BL2 141	105	232
2BL2 251	195	430
2BL2 281	210	463
2BL2 341	225	496

Type	Weight when filled with water	
	approx. [kg]	approx. [lbs]
2BL2 041	59	130
2BL2 061	97	214
2BL2 101	110	243
2BL2 141	161	355
2BL2 251	290	640
2BL2 281	305	673
2BL2 341	320	706

3.1.2 Filling capacity for operating liquid

Normal tap water should usually be used as operating liquid.

At ambient temperature < 10°C (< 50°F) there is a risk of freezing see Chapter "Temperatures", Pg. 10.

Type	max. [l]	max. [gal(US)]	max. [gal(UK)]
2BL2 041	22.5	5.95	4.95
2BL2 061	43.5	11.5	9.57
2BL2 101	43.5	11.5	9.57
2BL2 141	57.5	15.2	12.65
2BL2 251	101	26.7	22.2
2BL2 281	101	26.7	22.2
2BL2 341	101	26.7	22.2

3.1.3 Filling capacity for antiliming agent

Use pure granulated citric acid as antiliming agent. The specified filling quantities for citric acid refer to the medium filling of the separator with operating liquid.

Type	approx. [kg]	approx. [lbs]
2BL2 041	2	4.41
2BL2 061	4	8.82
2BL2 101	4	8.82
2BL2 141	5	11
2BL2 251	8	17.6
2BL2 281	8	17.6
2BL2 341	8	17.6

3.1.4 Filling quantity for anti-corrosive agent for longer shut-down

To ensure sufficient protection, the entire interior of the installed unit must be filled with anti-corrosive agent.

Type	[l]	[gal (US)]	[gal (UK)]
2BL2 041	0.6	0.159	0.132
2BL2 061	1.0	0.264	0.220
2BL2 101	1.0	0.264	0.220
2BL2 141	1.0	0.264	0.220
2BL2 251	5.5	1.453	1.210
2BL2 281	6.3	1.664	1.386
2BL2 341	7.0	1.849	1.540

3.1.5 Minimum distances for heat dissipation

The dimensions are shown in Fig. 3, Pg. 13.

Type	Minimum distance A	
	[m]	[ft]
2BL2 041	≥ 0.5	≥ 1.64
2BL2 061	≥ 0.7	≥ 2.30
2BL2 101	≥ 0.7	≥ 2.30
2BL2 141	≥ 0.8	≥ 2.60
2BL2 251	≥ 1.0	≥ 3.28
2BL2 281	≥ 1.0	≥ 3.28
2BL2 341	≥ 1.0	≥ 3.28

Type	Minimum distance B	
	[m]	[ft]
2BL2 041	≥ 1.4	≥ 4.59
2BL2 061	≥ 1.6	≥ 5.25
2BL2 101	≥ 1.6	≥ 5.25
2BL2 141	≥ 1.8	≥ 5.90
2BL2 251	≥ 1.9	≥ 6.23
2BL2 281	≥ 1.9	≥ 6.23
2BL2 341	≥ 1.9	≥ 6.23

Type	Minimum distance C	
	[m]	[ft]
2BL2 041	≥ 0.4	≥ 1.31
2BL2 061	≥ 0.4	≥ 1.31
2BL2 101	≥ 0.4	≥ 1.31
2BL2 141	≥ 0.4	≥ 1.31
2BL2 251	≥ 0.4	≥ 1.31
2BL2 281	≥ 0.4	≥ 1.31
2BL2 341	≥ 0.4	≥ 1.31

3.1.6 Spacing of securing eyes

The dimensions are shown in Fig. 3, Pg. 13.

Type	Distance D	
	[mm]	[in]
2BL2 041	360	14.2
2BL2 061	495	19.5
2BL2 101	495	19.5
2BL2 141	585	23
2BL2 251	715	28.1
2BL2 281	715	28.1
2BL2 341	715	28.1

Type	Distance E	
	[mm]	[inches]
2BL2 041	345	13.6
2BL2 061	450	17.7
2BL2 101	450	17.7
2BL2 141	570	22.4
2BL2 251	755	29.7
2BL2 281	755	29.7
2BL2 341	755	29.7

Type	Distance F	
	[mm]	[inches]
2BL2 041	---	---
2BL2 061	225	8.9
2BL2 101	225	8.9
2BL2 141	285	11.2
2BL2 251	377	14.8
2BL2 281	377	14.8
2BL2 341	377	14.8

3.1.7 Noise level

Emission sound pressure level L_{pA} according to noise standard ISO 2151 with reference to the basic standard ISO 3744. Measured at 1 m [3.28 ft] distance with moderate throttling (100 mbar abs. [1.45 psia]) and connected lines, tolerance ± 3 dB (A).

Type	1-m measuring-surface sound pressure level L [dB (A)]	
	bei 50 Hz:	bei 60 Hz:
2BL2 041	65	69
2BL2 061	69	73
2BL2 101	73	78
2BL2 141	75	78
2BL2 251	71	76
2BL2 281	73	78
2BL2 341	72	70

3.1.8 Operating speed

See rating plate.

3.1.9 Tightening torques

The values specified here for tightening torques apply unless other values are indicated.

 Tightening torques (Fig. 1, S. 3)			
Pos.:	Thread	[Nm]	[ft lbs]
005		2.7 - 3.3	1.99 - 2.43
007		10.8 - 13.2	8.0 - 9.7
012	E-JOT4	0.72 - 0.88	0.53 - 0.65
019	M8	13.5 - 16.5	9.96 - 12.2
019	M10	21.6 - 26.4	15.9 - 19.5
023	M8	8.1 - 9.9	6.0 - 7.3

 Tightening torques (Fig. 1, S. 3)			
Pos.:	Thread	[Nm]	[ft lbs]
023	M10	13.5 - 16.5	9.96 - 12.2
025		10.8 - 13.2	8.0 - 9.7
030	M6/M8	8.1 - 9.9	6.0 - 7.3
032	E-JOT5	1.1 - 1.3	0.8 - 0.96
032	M6	4.5 - 5.5	3.3 - 4.05
057	St 4,2	2.7 - 3.3	1.99 - 2.43
060	M6	2.7 - 3.3	1.99 - 2.43
066	E-JOT4	0.72 - 0.88	0.53 - 0.65
E	G $\frac{1}{4}$	2.25 - 2.75	1.66 - 2.0
E	G $\frac{3}{8}$	6.3 - 7.7	4.65 - 5.68
Clamps		2.7 - 3.3	1.99 - 2.43

 Tightening torques for screw connections (in general)			
Thread	Property classes	[Nm]	[ft lbs]
M4	5.6	1.26 - 1.54	0.93 - 1.14
M5	5.6	2.7 - 3.3	1.99 - 2.43
M6	8.8	7.2 - 8.8	5.3 - 6.5
M8	8.8	18 - 22	13.3 - 16.2
M10	8.8	36 - 44	26.6 - 32.5
M12	8.8	63 - 77	46.5 - 56.8
M16	5.6	90 - 110	66.4 - 81.1

(These values apply to screw connections with the exception of electrical connections.)

 Tightening torques for electrical connections (terminal board-connections)		
Thread	[Nm]	[ft lbs]
M4	0.9 - 1.1	0.66 - 0.81
M5	2.0 - 2.4	1.47 - 1.77
M6	2.7 - 3.3	1.99 - 2.43
M8	6.3 - 7.7	4.65 - 5.68
M10	10 - 12	7.34 - 8.85

(These values for electrical connections apply to all terminal board connections with the exception of terminal strips.)

3.2 Electrical data

See rating plate on separator water cooler.

3.3 Operating conditions

3.3.1 Default conditions

Ambient temperature	+20°C	+68°F
Ambient pressure	101.3 kPa	14.7 psi
Air saturation	50 %	

3.3.2 Temperatures

Temperatures of pumped gases/vapours		
Intake temperature	max. +60°C	max. +140 °F
Delivery temperature	≈ Ambient temperature	

Temperature of operating liquid	
max. +60°C	max. +140°F

Ambient temperature	
max. +40°C	max. +104°F
min. +10°C	min. +50°F
without antifreezer	

min. -20°C	min. 14°F
------------	-----------



At ambient temperature < 10°C (< 50°F) there is a risk of freezing.

Add antifreezer based on ethylene glycol (e.g. Antifrogen from Clariant) to operating liquid according to yellow label on cover plate (Item. 064, Pg. 3).

3.3.3 Pressures

Inlet pressure	
min. 5 kPa abs.	min. 0.725 psia
max. 80 kPa abs.	max. 11.6 psia

At inlet pressures > 35 kPa abs. [5.08 psia], the share of water vapour in the escaping gases may be slightly above that of the gases sucked in. The resulting water loss can automatically be compensated by a feed regulator (see Chapter 5.5, "Accessories", Pg. 19).

It is prohibited to connect piping to the discharge side of the system!

Discharge pressure	
approx. 101.3 kPa	approx. 14.7 psi
≈ Ambient pressure	

4 Transport and Handling

⚠ WARNING

Improper use of the system can result in serious or even fatal injuries!

Have you read the safety precautions in Chapter 1, "Safety", Pg. 4 f.? Otherwise you may not carry out any work with or on the system!

⚠ WARNING

Danger from tipping or falling loads!

Prior to transport and handling make sure that all components are securely assembled and secure or remove all components the fasteners of which have been loosened!

Manual handling:

⚠ WARNING

Danger from lifting heavy loads!

Manual handling of the unit is only permitted within the following limits:

- max. 30 kg [max. 66 lbs] for men
- max. 10 kg [max. 22 lbs] for women
- max. 5 kg [max. 11 lbs] for pregnant women

For the weight of the system, see Chapter 3.1, "Mechanical data", Section "Weight", Pg. 8.

Above these limits, suitable lifting equipment and/or means of transport must be used!

Transport with lifting equipment:

⚠ WARNING

Danger from tipping or falling loads!

When transporting with lifting equipment, observe the following basic rules:

- Use only suitable lifting gear (e.g. belts or ropes) and means of transport (e.g. forklift truck, low-lift platform truck, crane).
- The lifting capacity of lifting equipment and lifting gear must be at least equal to the system's weight.
For the weight of the system, see Chapter 3.1, "Mechanical data", Section "Weight", Pg. 8.
- The system must be secured so that it cannot tip or fall.
- Do not stand or walk under suspended loads!

Transport with a crane and lifting belts, with forklift truck or with low-lift platform truck.



Fig. 2: Attachment points

Attach the strap belts as shown in Fig. 2, Pg. 11:

- Use two lifting belts routed along below the system.
- The lifting belts should be securely seated in the recesses shaped into the lower edges (two on each of the long sides) of the system so as to prevent the system from slipping out of them.
- The lifting belts must be sufficiently long (spread angle smaller than 90°).
- Make sure that no damage is caused to any attached fittings.

5 Installation

⚠ WARNING

Improper use of the system can result in serious or even fatal injuries!
 Have you read the safety precautions in Chapter 1, "Safety", Pg. 4 f.? Otherwise you may not carry out any work with or on the system!

NOTE

For the system design, see Fig. 1, Pg. 3. The item numbers (Item) specified in the text refer to this illustration.

5.1 Installation

⚠ CAUTION

Danger of crushing from system tipping over!
 In the unmounted state, the system can easily tip due to its weight distribution!
 Wear gloves and safety shoes! Handle the system with the appropriate care!

⚠ CAUTION

Danger of tripping and falling!
 Make sure the system does not present a danger of tripping!
 Block off the system with a guard fence or mark with red-and-white tape etc. if necessary.

⚠ WARNING

Electrical danger!
 The system must be installed so that the electrical device cannot be damaged by external influences!
 In particular, the feed pipes must be securely routed, e.g. in cable ducts or in the floor.

CAUTION

Danger of damage to the system due to overheating!
 When installing the system, make sure that heat dissipation and cooling are not obstructed. The minimum distances specified in Chapter 3.1, "Mechanical data", Section "Minimum distances for heat dissipation", Pg. 8 must be complied with.
 Discharge air of other machines/devices may not be directly sucked in again!

⚠ WARNING

Danger from system tipping over or falling!
 If the system is installed on moveable machine parts or at a great height without any other protection against falling down, it must **by all means** be bolted to the bearing surface via the securing eyes in its feet.

NOTE

Note on later transport!
 Install the system with the feet on strips or similar supports to simplify transport later, e.g. with a low-lift platform truck!

Space requirement and minimum distances:

The space requirement and positioning of the hole for installing and securing the system are shown in Fig. 3, Pg. 11.

- For minimum clearances for heat dissipation and cooling, see Chapter 3.1, "Mechanical data", Section "Minimum distances for heat dissipation", Pg. 8.
- Spacing of securing eyes: see Chapter 3.1, "Mechanical data", Section "Spacing of securing eyes", Pg. 9.

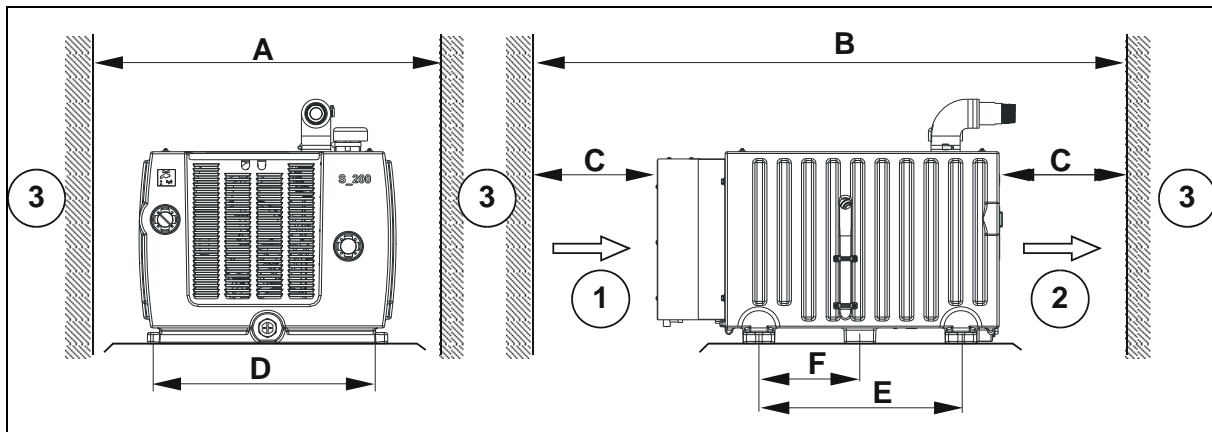

Fig. 3: Minimum distances for heat dissipation and spacing of securing eyes

A – C: Minimum clearance for heat dissipation
D – F: Spacing of securing eyes

See Chapter 3.1, "Mechanical data", Pg. 8 for dimensions.

1 Cooling air inlet
2 Cooling air outlet
3 Wall

Installation conditions:

The system must be installed as follows:

- on flat, level surfaces,
- on stationary (fixed) surfaces or structures,
- with the feet facing downward (no ringing off, e.g. with the feet on the wall),
- at a maximum height of 1000 m [3280 ft] above sea level.

At installation altitudes of more than 1,000 m [3,280 ft] above sea level, the Service Department must be consulted.

Observe the following when installing the system:

- The **load-bearing capacity** of the installation surface must at least be designed for the weight of the system.
- The **vibration behaviour at the operating location** must be taken into account. The total vibrations of the system are dependent on the following factors:
 - the characteristic vibrations of the system,
 - the alignment and installation,
 - the condition (vibration behaviour) of the load-bearing surface,
 - the influences by vibrations of other parts and system components (external vibrations).

The maximum permissible value for vibrations is $v_{\text{eff}} = 4.5 \text{ mm/s}$ [0.177"/s].

To ensure proper operation and a long service life of the system, this value may not be exceeded.

Generally, this value can be adhered to without a special foundation or a special base plate.

The points on the system for measuring the vibration speed are shown in Fig. 4, Pg. 13.



Fig. 4: Points for measuring the vibration speed

Securing:

There are two options:

- Install the system without securing.
- OR
- Screw the feet of the system to the surface with suitable fasteners.
 - Models 2BL2 041 - 141:
Screws 4 x M10
Washers as per ISO 7093-1
Tightening torque: 10 Nm [7.38 ft lbs]
 - Models 2BL2 251 - 341:
Screws 4 x M12
Washers as per ISO 7093-1
Tightening torque: 20 Nm [14.81 ft lbs]

⚠ CAUTION

With the 2BL2 341 the 4 adjustment screws of the hexagonal feet (see Fig. 1, Pg. 3) and the 3 strips of the separator must make contact over the entire contact surface on the floor or the raised sections.

5.2 Electrical connection (motor)

⚠ DANGER

Electrical danger!
Improper behaviour can result in severe injuries and damage!

⚠ DANGER

Electrical danger!
The electrical connection may be carried out by trained and authorised electricians only!

⚠ DANGER

Electrical danger!
Before beginning work on the system, the following measures must be carried out:

- Deenergise.
- Secure against being switched on again.
- Determine whether deenergised.
- Ground and short-circuit.
- Cover or block off adjacent energised parts.

⚠ DANGER

Electrical danger!
Replace loose connections, singed or burned cables immediately!

⚠ DANGER

Electrical danger!
Lay the electrical connecting cables so that they cannot be damaged by external influences and are free from tensile stress!

⚠ WARNING

Danger due to gauge pressure and vacuum!
Danger due to escaping fluid!
Before beginning work on the system or line:

- Interrupt supply of operating liquid.
- Vent lines (depressurise).

CAUTION

Incorrect connection of the motor can lead to serious damage to the system!

Regulations:
The electrical connection must be carried out as follows:

- according to the applicable national and local laws and regulations,
- according to the applicable system-dependent prescriptions and requirements,
- according to the applicable regulations of the utility company.

Electrical power supply:

Observe the rating plate.
It is imperative that the operating conditions correspond to the data given on the rating plate!

Deviations permissible without reduction in performance:

- ±5 % voltage deviation
- ±2 % frequency deviation

Fit connecting cable:

- Use a **flexible cable** as the electrical connecting cable.
- Open system:
Remove cover plate.



**Fig. 5: Remove cover plate:
Unscrew screws**

- Insert the connecting cable:
Thread the connecting cable into the cord grips on the side panel of the separator and push it through the cable inlet into the interior of the separator.

Route the connecting cable into the terminal box of the installed unit via the cable entry opening.

- In order to **relieve strain**, secure the connecting cable as follows:
 - via the cable gland on the terminal box of the installed unit
 - via the cord grips on the outside of the separator
 - Tightening torques: see Chapter 3.1, "Mechanical data", Section "Tightening torques", Pg. 9.



Fig. 6: Strain relief:
Cord grips on the outside of the separator

Connection to drive-motor terminal box:

Carry out the connection and the arrangement of the jumpers in accordance with the circuit diagram in the terminal box.

Connect the protective conductor to the terminal with the following symbol:



The electrical connection must be carried out as follows:

- The electrical connection must be permanently safe.
- There may be no protruding wire ends.

- Clearance between bare live parts and between bare live parts and ground: $\geq 5.5 \text{ mm}$ [0.217"] (at a nominal voltage of $U_N \leq 690 \text{ V}$).
- Tightening torques for terminal plate connections:
see Chapter 3.1, "Mechanical data", Section "Tightening torques", Pg. 9.
- Use suitable cable lugs.
- For terminals with clamping straps, the conductors must be inserted so that approximately the same clamping height results on both sides of the bar.
Individual conductors must therefore be bent into a U-shape or connected with a cable lug.
- All conductors under outer angled grounding brackets must be bent into a "U" shape.

This also applies to:

- the protective conductor,
- the outer ground conductor.

Both conductors can be recognised from their colour (green/yellow).

⚠ WARNING

Electrical danger!

Clearance between bare live parts and between bare live parts and ground:

at least **5.5 mm [0.217"]** (at a nominal voltage of $V_n \leq 690\text{V}$)

Make sure there are no protruding pieces of wire!

⚠ WARNING

Electrical danger!

The terminal box must be free from

- foreign bodies,
- dirt,
- humidity.

Terminal box cover and cable entries must be tightly closed so as to make them dustproof and waterproof.

Check for tightness at regular intervals.

For **motor overload protection**:

- Use motor circuit breakers.
- Set the motor circuit breakers to the nominal current specified on the rating plate.
- We recommend using slow-acting motor circuit breakers.

Close system:

- Fit cover plate.

⚠ WARNING

Danger from rotating external fan of installed unit!
Only operate the system with the protective screen and cover plate installed!

CAUTION

If the installed unit is run dry, the mechanical seal will be destroyed in a matter of seconds!
DO NOT switch on until the following conditions are met:

- The separator must be correctly filled with operating liquid.
- The interior of the installed unit must be filled with operating liquid.

Check direction of rotation:

- Make sure that the following conditions are met:
 - The separator must be correctly filled with operating liquid (watch fill level indicator).
 - The interior of the installed unit must be filled with operating liquid.
 - The separator cover plate must be mounted.

⚠ WARNING

Danger from vacuum!
If there is a danger that the system could suck in:

- Do not go near the inlet connection with long, open hair or loose fitting clothing,
- Do not look into the inlet connection or move your eyes in front of the inlet connection opening.

- Do NOT connect the intake line to the inlet connection yet.
- Briefly turn power ON.
If the rotating direction is correct, cooling air immediately exits from the protective screen.
- Turn power OFF again.
- If necessary, reverse the direction of rotation of the motor.

⚠ WARNING

Malfunctions can result in serious damage and injuries!
In case of conspicuous irregularities which indicate malfunctions, take the following measures:

- If in doubt, shut off the operating materials concerned immediately!
- Determine cause immediately and eliminate!

Also see Chapter 9, "Servicing", Pg. 25.

5.3 Filling

⚠ WARNING

Improper use of the system can result in serious or even fatal injuries!
Only operate the system

- for the purposes indicated under "Intended Use"!
- with the fluids specified under "Proper use"!
- with the values indicated under "Technical Data"!

⚠ WARNING

Danger from caustic or toxic fluids!
In case of corrosive or toxic fluids (operating liquid, pumped gases/vapours):
Enquiry with Service is **absolutely** necessary!
Wear appropriate personal protective equipment (protective gloves, safety goggles, respiratory protection) when working on or near the system.
If appropriate, attach appropriate warning sign(s) to the system, e.g. 'Warning! Corrosive materials!', 'Warning! Harmful or irritant material!' or 'Warning! Toxic material'.

Proceed as follows:

Fill the separator:

Fill operating liquid (usually ordinary tap water) into the separator via the fill opening (Item 007),
Filling amount: See Chapter 3.1, "Mechanical data", Pg. 8.



Fig. 7: Filling separator
Models 2BL2 041 - 141 (via the filling opening)



Fig. 9: Filling installed unit (via inlet connection)



Fig. 8: Filling separator
Models 2BL2 251 - 341 (via the filling opening)

Check the liquid level in the separator:

Check via the fill level indicator (Item 010). When doing so, watch the maximum operating liquid level.

NOTICE

Max. operating-liquid level:
Lower edge of the fill opening (Item 007) = level-indicator pointer at 1 (Item 010).
Do not fill the separator above this level!

When the unit is filled for the first time: Fill installed unit:

Pour additional operating liquid into the inlet connection (Item A) of the system so that operating liquid flows into the interior of the installed unit.

- Models 2BL2 041 - 2BL2 141:
1.5 l [0.396 gal (US); 0.330 gal (UK)]
- Models 2BL2 251 - 2BL2 341:
7.0 l [1.32 gal (US); 1.1 gal (UK)]

CAUTION

If the installed unit is run dry, the mechanical seal will be destroyed in a matter of seconds!
DO NOT switch on until the following conditions are met:

- The separator must be correctly filled with operating liquid.
- The interior of the installed unit must be filled with operating liquid.

⚠ WARNING

Danger due to escaping fluid!

Make sure that all openings in the separator (feed/drain regulator connection, fill opening, drain opening) are tightly closed (by means of screwed-in bung plugs or installed feed regulator, drain regulator and drain valve) when the separator is filled with operating liquid.

5.4 Connection of pipes/hoses

⚠ WARNING

Danger from vacuum!

Do not operate the unit unless the pipe / hose has been fitted to the inlet connection!

If there is a danger that the system could suck in:

- Do not go near the inlet connection with long, open hair or loose fitting clothing,
- Do not look into the inlet connection or move your eyes in front of the inlet connection opening.

⚠ WARNING

Danger from vacuum!

Danger due to escaping fluid!

During operation connected pipes and vessels are vacuumised!

Make sure that all connections are sufficiently tight! Use only pipes and vessels of sufficient strength!

The **pumped gases/vapours** are sucked in via the inlet connection (see Chapter 5.4.1, Pg. 18) and discharged via the exhaust-air connection (see Chapter 5.4.2, Pg. 19).

5.4.1 Inlet connection

Remove sealing plug

To prevent the penetration of foreign bodies, the connection opening on the inlet connection (Item A) is sealed off on delivery.

Do not remove the sealing plug until immediately before connecting the pipes/hoses.

Check valve:

In the following cases a check valve must be attached to the inlet connection (Item A):

- If two or more systems are operated in parallel, e.g. reserve system.
(Note: A separate check valve must be attached to the inlet connection on each system.)
- If a vacuum can occur for more than one minute in the connected intake line on the system switched off.

The check valve prevents the backflow of pumped gases/vapours from the system during an interruption in operation.

Connect the inlet pipe:

Connect the system-side line for the pumped gases/vapours (intake line) to the connecting piece of the inlet connection (Item 037).

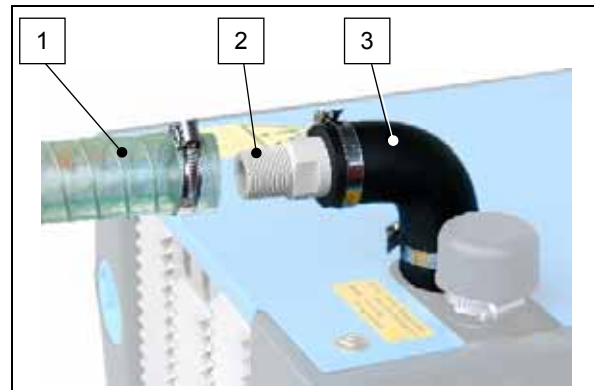

Fig. 10: Connection of inlet line on connecting piece of inlet connection

- 1 Inlet line
- 2 Connection thread
- 3 Connecting piece

CAUTION

Danger of damage to connecting piece!

The connection thread on the connecting piece of the inlet connection is made of plastic, and can therefore easily be damaged.

Exercise the appropriate caution when connecting the inlet line.

The tightening torque must always be adjusted to match the connection thread material.

NOTICE

Attach pipes/hoses free of mechanical tensions.
Support the weight of the pipes/hoses.

5.4.2 Exhaust-air connection

The pumped gases/vapours are expelled into the surrounding area via the exhaust-air connection (Item B). They are not directed through a pipe or a hose.

As a result, no assembly is required here.

CAUTION

Danger from excessive pressure!

Danger from system clogging!

Do not remove the protective cap from the exhaust-air connection!

NOTICE

If delivery-side piping is desired:
Enquiry with Service is **absolutely necessary!**

5.5 Accessories

The following accessories are available according to our catalogue:

- Suction-side through filter
- Vacuum Control Valve
- Feed Regulator
- Outlet Regulator
- Electrical Level Switch
- Drain Valve



Fig. 11: Accessories

6 Commissioning

⚠ WARNING

Improper use of the system can result in serious or even fatal injuries!

Have you read the safety precautions in Chapter 1, "Safety", Pg. 4 f.? Otherwise you may not carry out any work with or on the system!

⚠ WARNING

Danger from vacuum!

Danger due to escaping fluid!

Danger due to rotating parts!

The system may only be put into operation when the following conditions are met:

- The hoses on the inlet and discharge connection and on the operating liquid connection of the installed unit are connected.
- The cover plate and the water cooler of the separator are fitted.
- The lines and connection elements of the operating liquid circuit are fitted.
- The line on the system inlet connection is connected.
- The pipe/hose connections, pipes/hoses and vessels have been checked for sufficient strength and freedom from leaks!
- The fasteners have been checked for secure seating.

CAUTION

If the installed unit is run dry, the mechanical seal will be destroyed in a matter of seconds!

DO NOT switch on until the following conditions are met:

- The separator must be correctly filled with operating liquid.
- The interior of the installed unit must be filled with operating liquid.

NOTE

For the system design, see Fig. 1, Pg. 3. The item numbers (Item) specified in the text refer to this illustration.

- The interior of the installed unit must be filled with operating liquid.
- The separator cover plate must be mounted.

- Turn power ON.
- The system begins to intake the pumped gases/vapours.

NOTE

If, on being put into service for the first time, the system does not generate a vacuum: briefly throttle or close and reopen the inlet side.

6.2 Shut-down

Generally speaking, the system may be shut down in any operating condition (i.e. regardless of the actual pressure, temperature, etc.). Take into consideration, however, whether the process of your line allows for interrupting the operation of the system.

Proceed as follows:

- Turn power OFF.
- The system interrupts the intake of the pumped gases/vapours.

In case the unit is not to be put into service again for an extended period of time: observe the instructions in Chapter 8, "Shutting Down and Longer Standstill", Pg. 23.

6.1 Preparation and start-up

Proceed as follows:

- Make sure that the following conditions are met:
 - The separator must be correctly filled with operating liquid. (watch fill level indicator).

7 Operation

Start-up and shut-down in normal operation is identical to the procedure for commissioning.

⚠ WARNING
<p>Improper use of the system can result in serious or even fatal injuries!</p> <p>Have you read the safety precautions in Chapter 1, "Safety", Pg. 4 f.? Otherwise you may not carry out any work with or on the system!</p> <p>Also be sure to read the safety precautions in Chapter 6, "Commissioning", Pg. 20!</p>

NOTE
<p>For the system design, see Fig. 1, Pg. 3. The item numbers (Item) specified in the text refer to this illustration.</p>

7.1 Start-up and shut-down

See:

- Chapter 6.1, "Preparation and start-up", Pg. 20.
- Chapter 6.2, "Shut-down", Pg. 20.

7.2 Operation within the process

Continuous operation at maximum vacuum/minimum inlet pressure (with the inlet valve closed) is possible. The power consumption of the system is at its lowest in this case.

In case of no-load operation we recommend operation at minimum inlet pressure (lowest power consumption).

The following applies to models 2BL2 041 - 2BL2 141:

during operation at low inlet pressures (≤ 20 kPa abs. [2.90 psia]), the pumping capacity of the system can be increased by switching over the 3-way valve (Fig. 1, Pg. 3, Item G) to the HIGH VACUUM position.
(Also see Fig. 12, Pg. 21).

During operation at inlet pressures ≥ 20 kPa abs. [2.90 psia], this valve position can lead to the formation of splash water on the exhaust-air connection.

Switchover is not required for the models 2BL2 251 - 2BL2 341.

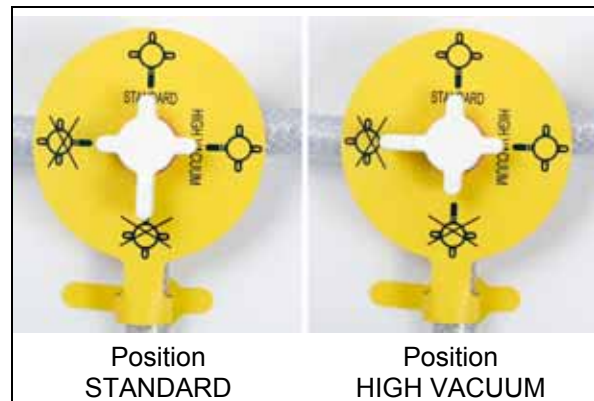

Fig. 12: 3-way valve (only 2BL2 041 - 141)

7.2.1 Loss of operating liquid

At a **low humidity** and a **high inlet pressure** (> 35 kPa abs. [5.08 psia]), the water vapour content in the escaping gases is slightly above that of the gases sucked in. This results in a slight **loss of operating liquid**.

NOTICE
<p>Check the operating-liquid level in the separator regularly by means of the level indicator!</p>

NOTICE
<p>Do not operate the system with the operating liquid level with the pointer in the 0 position!</p>

Liquid level with pointer in 0 position:

At a **liquid level with the pointer in the 0 position**, the pumping capacity of the system will be reduced. During longer operation under these conditions, this leads to a dip in the vacuum and may ultimately result in the system running dry!

When the pointer is in the 0 position (minimum), take the following measures:

- Interrupt system operation.
See Chapter 6.2, "Shut-down", Pg. 20.
- Pour operating liquid into the separator via the filling opening (up to pointer position 1 (lower edge of the filling opening)).

NOTICE
<p>Max. operating liquid level: Lower edge of the filling opening = level-indicator pointer at 1. Do not fill the separator above this level!</p>

Feed regulator:

In case of operating liquid loss, a feed regulator (see Chapter 5.5, "Accessories", Pg. 19) can be connected with which the liquid level is automatically compensated.

7.2.2 Increase in operating liquid

In case of **high air saturation** and **low inlet pressure**, the water vapour content of the discharge gases is slightly below that of the inlet gases. This results in a slight **increase in operating liquid**.

Also, **water entrained via the inlet pipe** will result in an **increase in operating liquid**.

NOTICE
Check the operating-liquid level in the separator regularly by means of the level indicator! Overfilling cannot be checked via the fill level indicator!

NOTICE
Do not operate the system with the operating liquid level above pointer position 1!

Outlet regulator:

In case of operating liquid increase, a drain regulator (see Chapter 5.5, "Accessories", Pg. 19) must be connected with which the liquid level is automatically compensated.

8 Shutting Down and Longer Standstill

WARNING

Improper use of the system can result in serious or even fatal injuries!

Have you read the safety precautions in Chapter 1, "Safety", Pg. 4 f.? Otherwise you may not carry out any work with or on the system!

NOTE

For the system design, see Fig. 1, Pg. 3. The item numbers (Item) specified in the text refer to this illustration.

8.1 Draining

DANGER

Electrical danger!

Before beginning work on the system, the following measures must be carried out:

- Deenergise.
- Secure against being switched on again.
- Determine whether deenergised.
- Ground and short-circuit.
- Cover or block off adjacent energised parts.

DANGER

Electrical danger!

Work on electrical installations may be carried out by trained and authorised electricians only!

WARNING

Danger from vacuum!

Danger due to escaping fluid!

Before beginning work on the system or line:

- Interrupt supply of operating liquid.
- Vent lines (depressurise).
- Shut down system and disconnect mains plug.
- The above safety precautions apply when working on the system or line.
- If the feed regulator is installed: Shut off the feed pipe. Remove the feed regulator.
- Remove the cover plate (Item 064) and protective grille (Item 058) from the separator.
- Have a suitable catch container ready.
- Open the following drain openings (see Fig. 1, Pg. 3):

- Drain opening on separator (Item 005)
- Drain cooler (Item. F)
- Drain installed unit (Item E)
- Allow the liquid to drain out.
- Close all drain openings again. (Tightening torques: see Chapter 3.1, "Mechanical data", Section "Tightening torques", Pg. 9.
- Remount the cover plate (Item 064) and protective grille (Item 058) on the separator.

8.2 Preparing for longer shut-down

Before a longer shut-down (from approx. 4 weeks) or in case of frost danger, proceed as follows:

- Drain system as described in Chapter 8.1, "Draining", Pg. 23.
- Have the cover plate (Item 064) and protective grille (Item 058) removed from the separator.
- Models 2BL2 041 - 2BL2 141: Disconnect pipe/hose from screw-in connecting sleeve (Item H) of installed unit. Models 2BL2 251 - 2BL2 341: Disconnect pipe/hose from condensation cooler (Item 031). To remove the pipe/hose, open the clip with special pliers or a screwdriver.
- Choose a suitable anti-corrosive agent. Use only anti-corrosive agent based on ethylene glycol (e.g. Antifrogen from Clariant).
- Pour the anti-corrosive agent into the open screw-in connecting sleeve (Item H) using a funnel or hose. (See Fig. 13, Pg. 24.) Filling amount: see Chapter 3.1, "Mechanical data", Section "Filling quantity for anti-corrosive agent for longer shut-down", Pg. 8. The entire interior of the installed unit must be filled with anti-corrosive agent.
- During filling turn the cooling fan by hand by approx. one turn.
- Reconnect the disconnected pipe/hose.
- Remount the cover plate (Item 064) and protective grille (Item 058) on the separator.
- You have two options for the standstill: Either the system remains connected in the line, or the system is removed for storage.



Fig. 13: Pouring anti-corrosive agent into installed unit (for models 2BL2 041 - 2BL2 141)



Fig. 14: Pouring anti-corrosive agent into installed unit (for models 2BL2 251 - 2BL2 341)

8.3 Storage conditions

This chapter applies in the following cases:

- New systems,
- Systems that are already installed in a system and were prepared for a longer standstill, as described in Chapter 8.2, "Preparing for longer shut-down", Pg. 23.

To prevent standstill damage during storage, the environment must provide the following conditions:

- dry,
- dust-free,
- low-vibration (effective value of vibration speed $v_{\text{eff}} \leq 0.2 \text{ mm/s}$ [0.008"/sec]).

Take the following measures for **commissioning following a longer standstill**:

- Measure the insulation resistance of the motor.
In case of values $\leq 1\text{k}\Omega$ per volt of nominal voltage, dry winding.
- Drain off the anti-corrosive agent via the drain opening of the installed unit, as described in Chapter 8.1, "Draining", Pg. 23.
Dispose of anti-corrosive agent in accordance with the manufacturer's specifications.
- Then clean the system:
Pour operating liquid into the system via the filling opening (Fig. 1, Pg. 3, Item 007).
If appropriate, Briefly operate the system to circulate the operating liquid in the system. See Chapter 6.1, "Preparation and start-up", Pg. 20.
Switch off the system again. See Chapter 6.2, "Shut-down", Pg. 20.
Drain the system. See Chapter 8.1, "Draining", Pg. 23.
- For new systems:
Install the system as described in Chapter 5, "Installation", Pg. 12.
Commission the system as described in Chapter 6, "Commissioning", Pg. 20.
- For systems that are already installed in a line:
Commission the system as described in Chapter 6, "Commissioning", Pg. 20.

⚠ DANGER

Electrical danger!

Work on electrical installations may be carried out by trained and authorised electricians only!

⚠ WARNING

Danger of slipping due to escaping operating liquid!

When draining the system, operating liquid will be discharged downward via the opening in the bottom of the separator. Have a catch container ready under the system.

9 Servicing

WARNING

Improper use of the system can result in serious or even fatal injuries!

Have you read the safety precautions in Chapter 1, "Safety", Pg. 4 f.? Otherwise you may not carry out any work with or on the system!

WARNING

Improper use of the system can result in serious or even fatal injuries!

All maintenance work on the system must always be performed by the Service Department!

Maintenance work on the system may only be conducted by the operator itself when the related **maintenance manual** on hand! Inquire with the Service Department!

WARNING

Improper use of the system can result in serious or even fatal injuries!

Do not disassemble unless the system has been shut down and come to a complete standstill!

Consider that the system has a certain run-out! Only the following components may be removed:

- The hoses on the inlet and discharge connection and on the operating liquid connection of the installed unit
- The cover plate and the water cooler of the separator
- The pipes/hoses and connection elements of the operating-liquid circuit
- The line on the system inlet connection

WARNING

Danger from rotating impeller of installed unit!

The unit installed in the system may be neither removed nor dismantled!

WARNING

Cutting hazard!

Do not remove the protective grille from the water cooler!

DANGER

Electrical danger!

Before beginning work on the system, the following measures must be carried out:

- Deenergise.
- Secure against being switched on again.
- Determine whether deenergised.
- Ground and short-circuit.
- Cover or block off adjacent energised parts.

DANGER

Electrical danger!

Replace loose connections, singed or burned cables immediately!

DANGER

Electrical danger!

Work on electrical installations may be carried out by trained and authorised electricians only!

DANGER

Electrical danger!

Do not open the motor terminal box until absence of electricity has been ensured!

WARNING

Danger from vacuum!

Danger due to escaping fluid!

Before beginning work on the system or line:

- Interrupt supply of operating liquid.
- Vent lines (depressurise).

WARNING

Danger from rotating external fan of installed unit!

Only operate the system with the protective screen and cover plate installed!

WARNING

Danger of burns and scalding from hot surfaces of the installed unit and from hot fluids!

Only operate the system with the protective screen and cover plate installed! Allow to cool after shut-down!

⚠ WARNING

Improper use of the system can result in serious or even fatal injuries!

- Do not reach into the installed unit through the opened intake or discharge connection!
- Do not insert objects into the installed unit through the openings!

⚠ WARNING

Danger from tipping or falling loads!

If the system is installed on moveable machine parts or at a great height without any other protection against falling, the following applies:

- If the screw connection to the installation surface is unscrewed for maintenance work, then the system must be placed on a flat, rigid (stationary) surface.
- If appropriate, secure the system against falling from a great height.

⚠ WARNING

Improper use of the system can result in serious or even fatal injuries!

Do not disassemble unless the system has been shut down and come to a complete standstill!
Consider that the system has a certain run-out!
Only restart when the following conditions are met:

- The system is completely assembled.
- The pipe/hose connections, pipes/hoses and vessels have been checked for sufficient strength, freedom from leaks and secure seating!
- The fasteners have been checked for secure seating!

NOTE

For the system design, see Fig. 1, Pg. 3. The item numbers (Item) specified in the text refer to this illustration.

9.1 Maintenance

The system is largely maintenance-free.

The following maintenance work is necessary:

- If limy water is used as the operating liquid, the operating liquid must be softened or the entire system must be decalcified at regular intervals.
- Check the hoses and hose connections for any leaks and for firm seating!
- If dirt or solid materials (e.g. dust or sand) of lime deposits enter the system through the operating liquid and/or the pumped gases/vapours, it must be cleaned at regular intervals. This will prevent impeller jamming as well as the wear of individual system components.

Refer to the following table:

Contamination/Problem	Remedy
Water consumption increases considerably after an extended period of operation.	Clean cooling fins of water cooler. To do so, proceed as follows: <ul style="list-style-type: none"> • Carry out protective measures for the use of compressed air: <ul style="list-style-type: none"> – wear personal protective equipment (protective gloves and safety goggles), – secure surrounding area. • blow compressed air through cooling fins of water cooler (Item 027). Replace water filter (Item 095) and air filter (Item 096).
Ambient air is highly contaminated.	Clean cooling fins of water cooler (Item 027) regularly. See "Water consumption increases considerably after an extended period of operation".

Contamination/Problem	Remedy
Dirt particles (e.g. dust) enter system with pumped gases/vapours and collect in separator.	<p>Clean separator.</p> <p>Clean separator (Item 001) regularly (interval is dependent on concentration of dirt particles in pumped gases/vapours):</p> <ul style="list-style-type: none"> • Shut down system. • Drain system as described in Chapter 8.1, "Draining", Pg. 23. • Purge separator with clean water. • When using cleaning agents, you must consult Service Department. • If appropriate, Replace water filter (Item 095) and air filter (Item 096). <p>OR</p> <ul style="list-style-type: none"> • Connect inlet filter (see Chapter 5.5, "Accessories", Pg. 19) upstream on inlet side of system. • If appropriate, Replace water filter (Item 095) and air filter (Item 096).
Fine-grain dirt (e.g. sand) enters installed unit with operating liquid or pumped gases/vapours.	<p>Clean installed unit.</p> <p>Clean installed unit (Item D) at regular intervals. (Intervals are dependent on degree of soiling, approx. 1x per year.) To do so, proceed as follows:</p> <ul style="list-style-type: none"> • Shut down system and secure against being switched on again. • Remove cover plate (Item 064) and protective grille (Item 058). • Have a catch container ready under the system. • Open drain hole G$\frac{1}{4}$ (Item E) of installed unit. Then operating liquid flows out. It is discharged downward via the opening in the bottom of the separator. • WARNING: Danger from rotating external fan of installed unit! To ensure safety, remount the cover plate (Item 064) and protective grille (Item 058) on the separator! • Briefly switch on system. Dirt will be flushed out of installed unit along with operating liquid and will be discharged downward through opening in bottom of separator. • Shut down system again, secure and open as described above. • Close drain hole G$\frac{1}{4}$ (Item E) of installed unit again. • Completely reassemble system.
Impeller of installed unit is jammed.	<p>Free shaft by turning.</p> <p>To do so, proceed as follows:</p> <ul style="list-style-type: none"> • Shut down system and secure against being switched on again. • Remove cover plate (Item 064). • Turn shaft of installed unit (Item D) by hand at fan impeller. • If shaft cannot be freed by turning, installed unit must be decalcified.
Extremely hard water used as operating liquid Lime content > 15°dH).	<p>Soften operating liquid.</p> <p>OR</p> <p>Decalcify the entire system.</p> <p>To do so, proceed as follows:</p> <ul style="list-style-type: none"> • Use citric acid as antiliming agent. • Pour citric acid into system via filling opening (Item 007). Filling quantity of pure citric acid (in the form of granules), the system being at a medium operating-liquid level: See Chapter 3.1, "Mechanical data", Section "Filling capacity for antiliming agent", Pg. 8. • Operate system approx. 10 h with operating liquid with citric acid added. Citric acid will dissolve lime in the process. • Then drain system as described in Chapter 8.1, "Draining", Pg. 23. • Flush system several times with clean water.

9.2 Repairs/troubleshooting

NOTE

If the fault cannot be eliminated using the fault table etc., it is necessary to consult the Service Department.

NOTICE

During assembly, the tightening torques of the screws/bolts according to Chapter 3.1, "Mechanical data", Section "Tightening torques" Pg. 8, must be observed.

NOTICE

Have spare parts installed **exclusively** by the Service Department!

Fault	Cause	Remedy	Carried out by
Motor does not start, no running noise.	At least two power supply leads interrupted.	Eliminate interruption by fuses, terminals or supply cables.	Electrician
Motor does not start, humming noises.	One power supply lead interrupted.	Eliminate interruption by fuses, terminals or supply cables.	Electrician
	Impeller of installed unit is jammed.	Free shaft by turning. See Chapter 9.1, "Maintenance", Section "Free shaft by turning", Pg. 27.	Operator/ Service
		Decalcify entire system. See Chapter 9.1, "Maintenance", Section "Decalcify the entire system", Pg. 27.	Operator
Protective motor switch trips when motor is switched on.	Protective motor switch setting too low.	Set the protective motor switch to the rated current indicated on the rating plate.	Electrician
	Winding short-circuit.	Have winding checked.	Electrician/ Service Dept.
	Counter pressure at discharge connection too high.	Check exhaust-air connection (Item B) and condensation cooler (Item 031) for soiling.	Operator/ Service
	Impeller of installed unit is jammed.	See "Motor does not start, humming noises".	Operator/ Electrician/ Service Dept.
Power consumption too high.	Lime or other deposits.	Decalcify entire system. See Chapter 9.1, "Maintenance", Section "Decalcify the entire system", Pg. 27.	Operator
		Clean installed unit. See Chapter 9.1, "Maintenance", Section "Clean installed unit", Pg. 27.	Operator
		Clean separator. See Chapter 9.1, "Maintenance", Section "Clean separator", Pg. 27.	Operator
System does not generate vacuum.	No operating liquid.	Fill in operating liquid via the fill opening (Item 007) as described in Chapter 5.3, "Filling", Pg. 16".	Operator
	Severe leak in system.	Seal off leak in system.	Operator
	Severe leak in system.	Seal off leak in system.	Operator
	Wrong direction of rotation.	Reverse direction of rotation by interchanging two connecting leads.	Electrician

Fault	Cause	Remedy	Carried out by
System generates insufficient vacuum.	System too small.	Use larger system.	Operator
	Inlet pipe too long or of too small diameter.	Use shorter pipe or pipe of larger diameter for the inlet pipe.	Operator
	Hose connections on inlet side or inlet pipe leaky.	Check hose connections on the inlet side and inlet pipe and seal leak if necessary.	Operator
	Operating-liquid flow too low.	Check operating liquid pipe (Item 043) and operating liquid hole (Item J) of installed unit for clogging. If necessary, eliminate clogging.	Operator/Service
	Too little operating liquid in the separator.	Top up operating liquid.	Operator
	Operating liquid too warm (nominal temperature: 15°C).	Cooling fins of water cooler (Item 027) are soiled; clean. See Chapter 9.1, "Maintenance", Section "Clean cooling fins of water cooler", Pg. 26.	Operator
	Slight leak in the system.	Seal leak in the system.	Operator
	Inlet filter (accessory) clogged.	Replace inlet filter.	Operator
	Vacuum control valve (accessory) incorrectly set.	Check and, if necessary, correct setting of the vacuum control valve.	Operator
Drops of water squirting out of discharge connection.	Condensate is no longer drawn off.	Check air filter (Item 096) for clogging and clean or replace, if necessary.	Operator/Service
		Clean restrictor sleeves (Item 079 and 080). Proceed as follows: <ul style="list-style-type: none"> Shut down system and secure against being switched on again. Remove cover plate (Item 064) and protective grille (Item 058). Detach the hose connections in question. Clean restrictor sleeves (Item 079 and 080). Blow compressed air through the hoses leading to the condensation cooler (Item 031). Check hose connections on condensation cooler (Item 031) for clear passage. Reassemble components. 	Operator/Service
	Liquid level in the separator too high (level indicator ≥ 1).	If water is entrained via the inlet connection install automatic discharge regulator (accessory). Check if feed regulator (accessory) works correctly.	Operator Operator
Major increase in water consumption compared to condition when new.	Throttle valves are choked.	Clean restrictor sleeves (Item 079 and 080). See "Drops of water squirting out of discharge connection".	Operator/Service
	Air filter or water filter clogged.	Replace air filter (Item 096) or water filter (Item 095).	Operator/Service
		Clean separator (Item 001) if necessary. See Chapter 9.1, "Maintenance", Section "Clean separator", Pg. 27.	Operator
	Cooling fins of water cooler soiled.	Clean cooling fins of water cooler (Item 027). See Chapter 9.1, "Maintenance", Section "Clean cooling fins of water cooler", Pg. 26.	Operator
	Room temperature higher than permissible.	Enquire with Service Department.	Operator/Service

Fault	Cause	Remedy	Carried out by
Abnormal screeching noise.	Cavitation of installed unit.	Check connection of cavitation protection hole (Item K) and condensate pipe (Item 041) for clogging. See "Drops of water squirting out of discharge connection".	Operator/ Service
		3-way valve (Item G) may not be accurately adjusted. Check position of the 3-way valve and correct, if necessary.	Operator

*) Only when the maintenance manual is at hand: rectification by the operator.

9.3 Service/After-sales service

Our Service is available for work (in particular the installation of spare parts, as well as maintenance and repair work), not described in these operating instructions (see front page of these operating instructions).

Observe the following when **returning** systems:

- Before shipping:
 - Drain system completely as described in Chapter 8.1, "Draining", Pg. 23.
 - Clean system outside (observe degree of protection according to rating plate when doing so)
- The system must be delivered complete, i.e. not dismantled.
- Only the original packing should be used for shipment.
- A declaration of clearance must be included with the shipment, as described in Chapter 9.4, "Decontamination and Declaration of Clearance", Pg. 30.
- The original rating plate of the system must be properly mounted, intact and legible. All warranty claims are voided for systems delivered for a damage expertise without the original rating plate or with a destroyed original rating plate.
- In case of warranty claims, the manufacturer must be informed of the operating conditions, operating duration etc. and additional detailed information provided on request if necessary.

9.4 Decontamination and Declaration of Clearance

⚠ WARNING
<p>Danger from flammable, caustic or toxic substances!</p> <p>To protect the environment and persons, the following applies:</p> <p>Systems which have come into contact with dangerous substances must always be decontaminated before being passed on to a workshop!</p>

A so-called **Declaration of Clearance** must be included with each system that is given to a workshop for inspection, maintenance or repair.

The declaration of clearance

- is provided as a pre-printed form for photocopying Pg. 33,
- is legally binding,
- must be filled out and signed by authorised, qualified personnel,
- must be issued for each system sent in (i.e. a separate declaration for each system),
- must be attached outside on the packing of the system,
- should be sent to as a copy by fax the workshop conducting the work prior to shipment.

This ensures

- that the system has not come into contact with dangerous substances,
- that a system that has come into contact with dangerous substances has been sufficiently decontaminated,
- that the inspection, maintenance or repair personnel can take the required protective measures if necessary.

NOTICE

The inspection/maintenance/ repair of the system at the workshop will not be begun until the declaration of clearance has been received!

If the declaration of clearance is not included with the shipment, delays may result!

10 Disposal

Have the entire system scrapped by a suitable disposal company. No special measures are required when doing so.

For additional information on disposing of the system, ask the Service Department.

EU declaration of conformity



Manufacturer: Gardner Denver Deutschland GmbH
Industriestraße 26
97616 Bad Neustadt
Germany

Responsible for documentation: Holger Krause
Industriestraße 26
97616 Bad Neustadt
Germany

Designation: compressor/vacuum pump
Series L-BL2
Types 2BL2041 2BL2061
2BL2101 2BL2141
2BL2251 2BL2281
2BL2341

The machine described above meets the following applicable Community harmonisation legislation:

2006/42/EC Directive 2006/42/EC of the European Parliament and of the Council of 17 May 2006 on machinery, and amending Directive 95/16/EC

Harmonised standards applied:

- EN 1012-1:2010** Compressors and vacuum pumps - Safety requirements - Part 1: Air compressors
- EN 1012-2:1996 +A1:2009** Compressors and vacuum pumps - Safety requirements - Part 2: Vacuum pumps
- EN ISO 12100:2010** Safety of machinery - General principles for design - Risk assessment and risk reduction
- EN 60204-1:2006** Safety of machinery - Electrical equipment of machines Part 1: General requirements
- EN 60034-1:2010/ AC: 2010** Rotating electrical machines - Part 1: Rating and performance IEC 60034-1:2010 (amended)

Bad Neustadt, 30.09.2013
(Place and date of issue)

Andreas Bernklau, Product management/Authorised signatory
(Name and function)

Dr. Rudi Dittmar, Development
(Name and function)

664.44444.40.000



Statement on health safety and on the protection of the environment

- For the safety of our employees and to comply with statutory requirements on handling substances harmful to the health and the environment, this statement must be enclosed, fully completed, with each unit/system sent.
• Without the fully completed statement, repair/disposal is not possible and delays are unavoidable!
• The statement is to be completed and signed by suitably qualified, authorised personnel at the operating organisation.
• In the case of shipment to Germany, the statement is to be completed in German or English.
• The statement is to be attached to the outside of the packing on shipment.
• If necessary, the carrier is to be informed.

- 1. Product designation (type):
2. Serial number (no. BN):
3. Reason for sending:

- 4. The unit/system
[] has not come into contact with hazardous substances. There will be no hazards for personnel or the environment during repair/disposal. Continue with "6. Legally binding statement"
[] has come into contact with hazardous substances. Continue with "5. Information on the contamination"

- 5. Information on the contamination (if necessary provide more information on an additional sheet)
The unit/system was used in the following application:

and has come into contact with the following classifiable substances or substances presenting a hazard to health/environment:

Table with 4 columns: Trade name, Chemical designation, Hazardous substance class, Properties (e.g. toxic, inflammable, caustic, radioactive)

- [] The unit/system has been emptied in accordance with the operating instructions, flushed and cleaned externally.
[] Safety data sheets in accordance with the applicable regulations are enclosed (sheet).
[] The following safety precautions are necessary for handling (e.g. personal protective equipment):

6. Legally binding statement

I herewith guarantee that the details specified are true and complete and that I, as signatory, am in a position to judge that this is so.
We are aware that we are liable to the contractor for any damages arising from incomplete or incorrect specifications. We are obliged to indemnify the contractor against claims for damages by third parties arising from incomplete or incorrect specifications. We are aware that, irrespective of this statement, we are directly liable to third parties - in particular including the contractor's employees tasked with repair/disposal.

Company/institute:
Name, position: Phone:
Street: Fax:
Post code, city:
Country: Stamp:
Date, signature:



www.gd-elmorietschle.de
er.de@gardnerdenver.com

Gardner Denver
Deutschland GmbH
Industriestraße 26
97616 Bad Neustadt · Deutschland
Tel. +49 9771 6888-0
Fax +49 9771 6888-4000

Gardner

Denver

Elmo Rietschle is a brand of
Gardner Denver's Industrial Products
Group and part of Blower Operations.