



Radialgebläse
Saugausführung

Radial blowers
Vacuum version

Turbines centrifuges
Exécution aspiration

Soffianti radiali
Esecuzione aspirante

F-CEV-S...

F-CEV 3709-S3

F-CEV 3709-S4

F-CEV 3709-S5

F-CEV 3718-S3

F-CEV 3718-S4

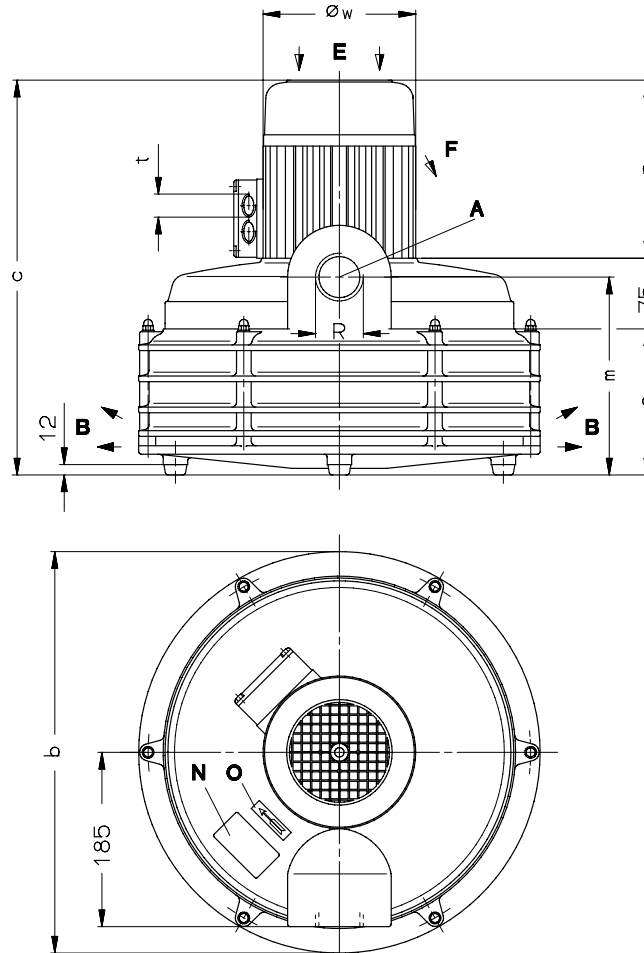

[mm]

A	Saug-Anschluss	Vacuum connection	Raccord dépression	Attacco aspirazione
B	Abluft-Austritt	Exhaust	Refolement	Scarico aria
E	Kühlluft-Eintritt	Cooling air entry	Entrée air refroidissement	Entrata aria di raffreddamento
F	Kühlluft-Austritt	Cooling air exit	Sortie air refroidissement	Uscita aria di raffreddamento
N	Datenschild	Data plate	Etiquette caractéristique	Targhetta dati
O	Drehrichtungsschild	Direction of rotation	Flèche sens rotation	Targhetta senso rotazione

F-CEV		3709-S3	3709-S4	3709-S5	3718-S3	3718-S4
[mm]	b	426	426	426	446	446
	c	420	453	508	491	541
	m	211	244	277	260	308
	o	156	189	222	205	253
	r	189	189	211	211	213
	t	M 20 x 1,5	M 20 x 1,5	M 20 x 1,5	M 20 x 1,5	M 25 x 1,5
	øw	162	162	162	162	180
	R	G 2	G 2	G 2	G 3	G 3

D 702

1.1.2004

**Gardner Denver
Schopfheim GmbH**

Postfach 1260

79642 SCHOPFHEIM
GERMANY

Fon +49 7622 / 392-0

Fax +49 7622 / 392-300

e-mail: er.de@
gardnerdenver.com

www.gd-elmorietschle.com

F-CEV		3709-S3	3709-S4	3709-S5	3718-S3	3718-S4
3~	50 Hz	230/400V ± 10%				
	60 Hz	220/380V				
kW	50 Hz	0,55	0,75	1,1	1,1	1,5
	60 Hz	0,65	0,90	1,3	1,3	1,8
A	50 Hz	2,85/1,65	5,4/3,1	5,2/3,0	5,4/3,1	6,1/3,5
	60 Hz	4,0/2,3	4,5/2,6	5,9/3,4	#	8,15/4,7
min ⁻¹	50 Hz	2850				
	60 Hz	3450				
dB(A)	50 Hz	72	73	73	75	75
	60 Hz	73	74	74	76	76
kg		30	38	42	38	42
ZMS	50 Hz	40/24	60/40	60/40	60/40	100/40
	60 Hz	40/24	60/40	60/40	#	100/60

m ³ /min	Volumenstrom	Capacity	Volume engendré	Portata volumetrica
mbar	Druckdifferenz	Pressure difference	Pression différentielle	Differenza di pressione
V	Vakuumbetrieb	Vacuum operation	Fonction dépression	Esercizio in aspirazione
3~	Motorausführung	Motor version	Exécution moteur	Esecuzione motore
kW	Motorleistung	Motor rating	Puissance moteur	Potenza motore
A	Stromaufnahme	Current drawn	Intensité absorbée	Corrente nominale
min ⁻¹	Drehzahl	Speed	Vitesse rotation	Numero giri
dB(A)	Mittlerer Schallpegel	Average noise level	Niveau sonore moyen	Rumorosità media
kg	Max. Gewicht	Maximum weight	Poids maxi.	Peso massimo
ZMS	Zubehör	Optional extras	Accessoires	Accessori
	Motorschutzschalter	Motor starter	Disjoncteur moteur	Interruttore magnetotermico

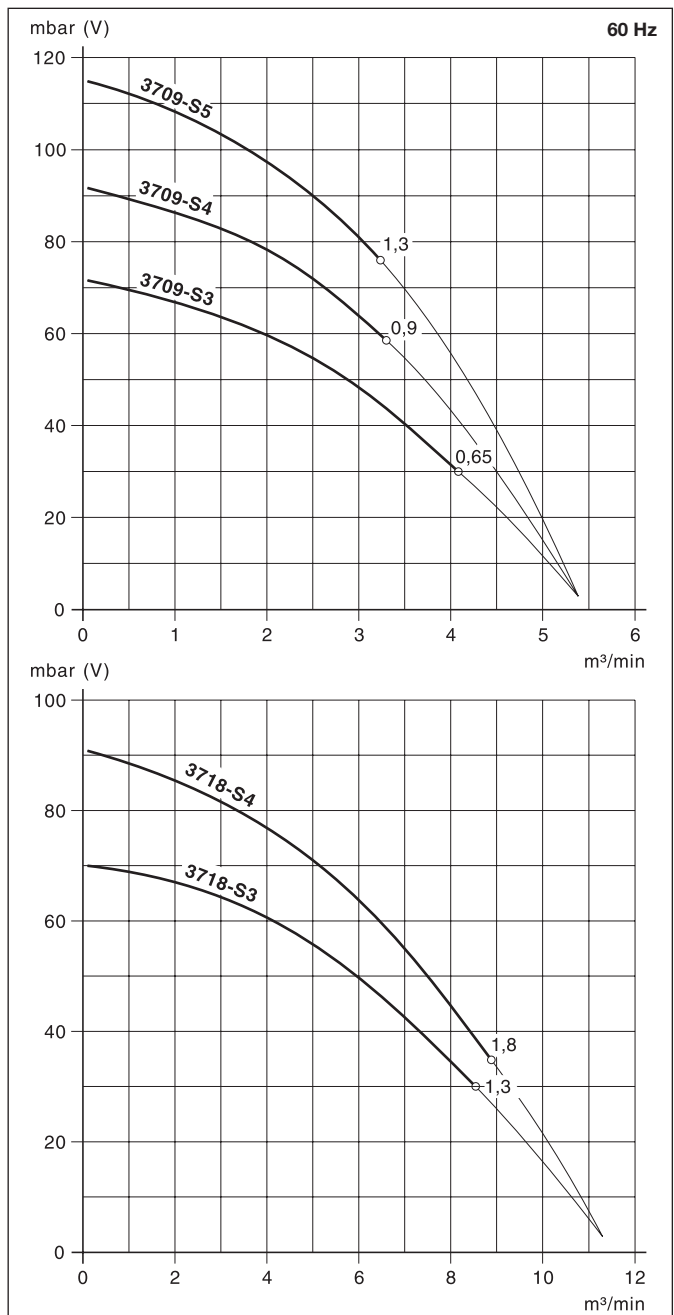
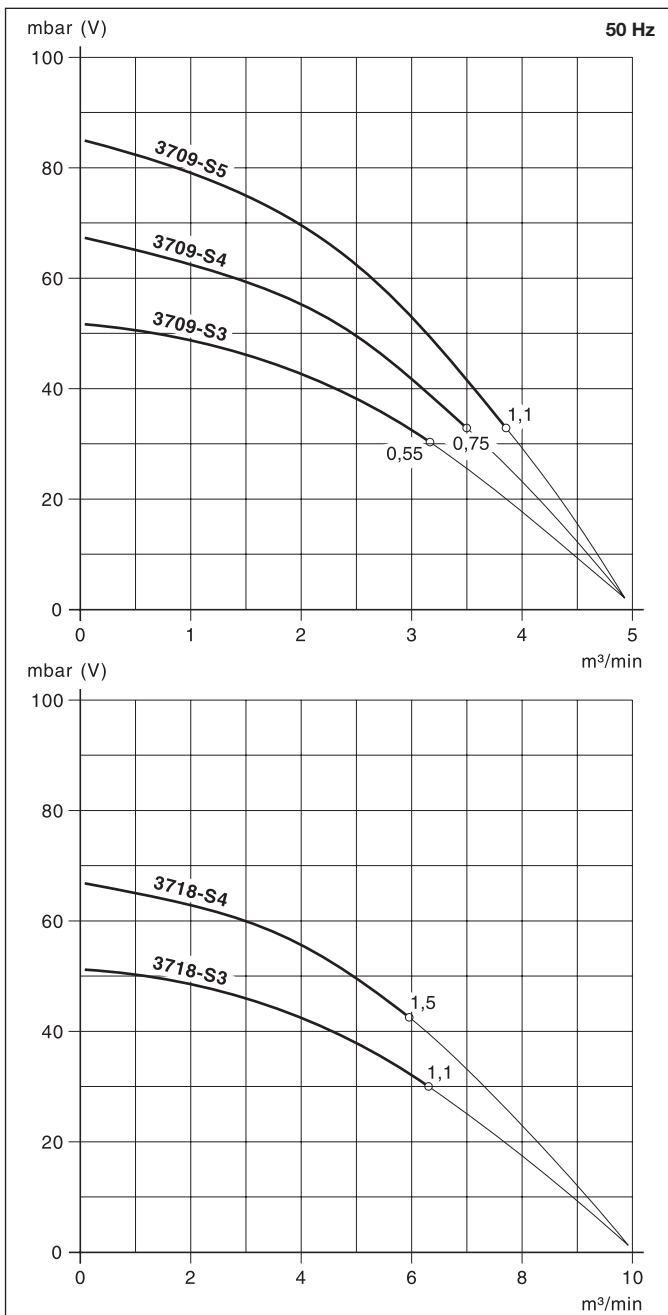

Die Kennlinien haben eine Toleranz von ± 10% und beziehen sich auf freie atmosphärische Luft von 1 bar (abs.) und 20°C./ The curves have a tolerance of ± 10% and refer to free atmospheric air at 1 bar (abs.) and 20°C./ Les courbes ont une tolérance de ± 10% et sont établies à l'atmosphère de 1 bar (abs.) à 20°C./ Le curve hanno una tolleranza del ± 10% e si riferiscono alla pressione atmosferica di 1 bar (ass.) e 20°C. # auf Anfrage # on request # sur demande # a richiesta

Technische Änderungen vorbehalten! / We reserve the right to alter technical information! / Sous réserve de modification technique! / Salvo modifiche tecniche!